

Name (please print): \_\_\_\_\_ Total points: \_\_\_/100

**Instructions**

This is a CLOSED BOOK and CLOSED NOTES exam. However, you may use calculators, scratch paper, and the green MIPS reference card from your textbook. Ask the instructor if you have any questions. Good luck!

1. (20 points)

Intel is considering two different possible enhancements to their newest i7 line of processors. They only have enough time to implement one of these enhancements before the scheduled release date of the processor.

The instruction set of their original processor can be divided into three different types of instructions having the following CPIs:

Instruction type	CPI
A	1.4
B	2.4
C	2

The benchmarks that are used to evaluate processor performance consist of the following instruction mixture:

Instruction type	Percentage
A	25%
B	70%
C	5%

Intel must choose one of the following options:

1. decrease the CPI of instruction type A by a factor of 5 (divide the CPI by 5),  
or
2. decrease the CPI of instruction type B by a factor of 2 (divide the CPI by 2).

These enhancements will not affect the number of instructions or the clock rate. Which enhancement is preferable? You must justify your answer numerically (with calculations).

2. (10 points)

Provide all control signals for a ADD instruction using the following processor design. Assume ALUOp is 10 for interpretation of instruction function code, 00 for add, and 01 for subtract.

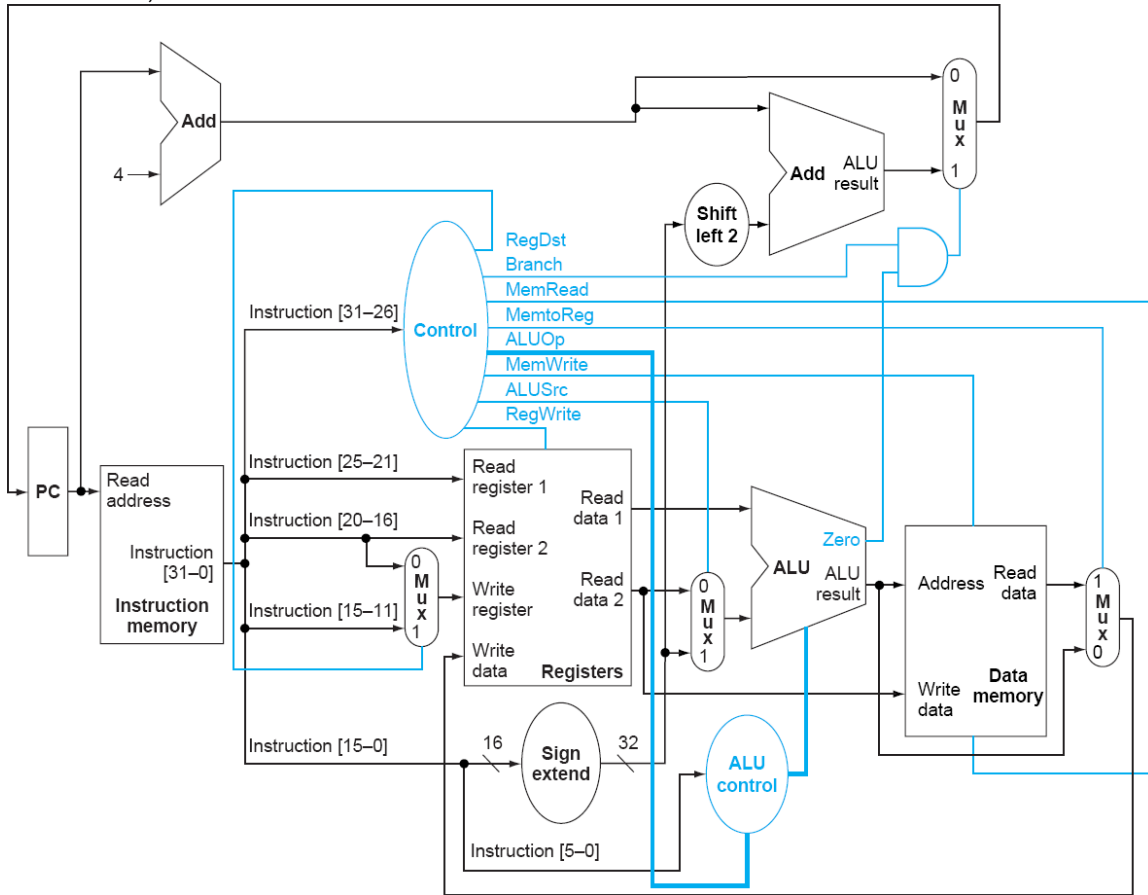

RegDst	_____	MemWrite	_____
Branch	_____	ALUSrc	_____
MemRead	_____	RegWrite	_____
MemtoReg	_____		
ALUOp	_____		

3. (20 points)

Describe how the above design would need to be modified in order to add the **JR** instruction. Recall that this instruction moves the contents of the register addressed by the "rs" field (bits 25 down to 21) into the program counter (PC). It is an R-type instruction.

