

Designer: Dr. James P. Davis
 Design Name: ALU_4_bit
 Version: v.02
 Date: 05 February 2003
 Table Type: Block Table

Block Name	Block Type	Comment(s)	Binding
ALU_4bit	Architectural - Local	N	N/A
Test_Harness	Architectural - Local	N	N/A
ALU_1bit	Architectural - Local	N	N/A
Block_4	Architectural - Reference	N	ALU_1bit
Block_5	Architectural - Reference	N	ALU_1bit
Block_6	Architectural - Reference	N	ALU_1bit
ALU_1bit_Function_Decoder	Textual - Local	N	/acct/fl/jimdavis/SUN/jdavis/courses/csce612-spring03/ALU_1bit_Function_Decoder.txt
ALU_1bit_Full_Adder	Textual - Local	N	/acct/fl/jimdavis/SUN/jdavis/courses/csce612-spring03/ALU_1bit_Full_Adder.txt
ALU_1bit_Logic_Functions	Textual - Local	N	/acct/fl/jimdavis/SUN/jdavis/courses/csce612-spring03/ALU_1bit_Logic_Functions.txt
ALU_1bit_Input_Control	Textual - Local	N	/acct/fl/jimdavis/SUN/jdavis/courses/csce612-spring03/ALU_1bit_Input_Control.txt
Output_OR	Textual - Local	N	/acct/fl/jimdavis/SUN/jdavis/courses/csce612-spring03/Output_OR.txt

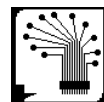

Block Browser

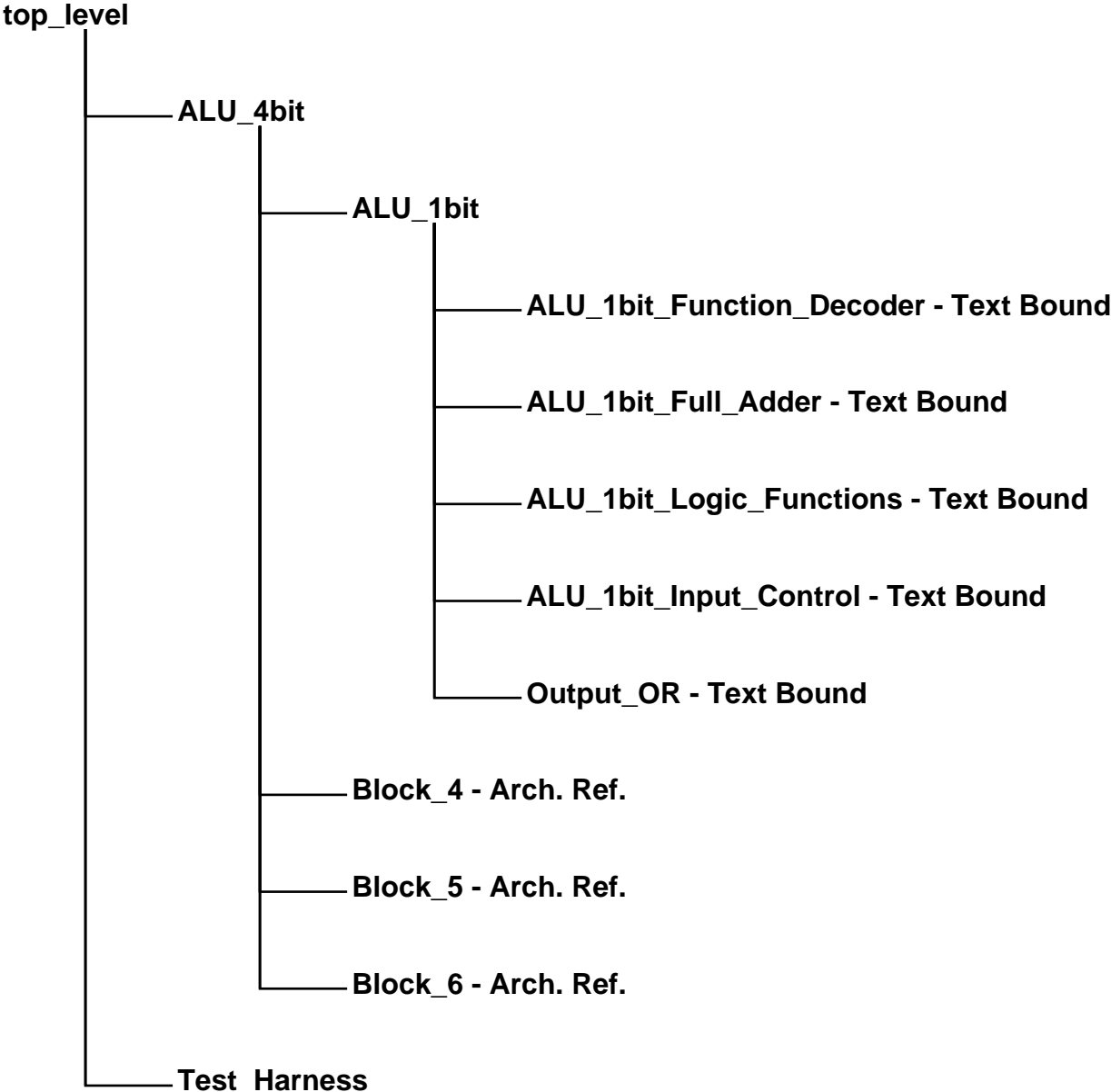

Designer : Dr. James P. Davis

Date : 05 February 2003

Page No. : 7 of 14

Design Name : ALU_4_bit

Version : v.02

Knowledge Based Silicon Corp.



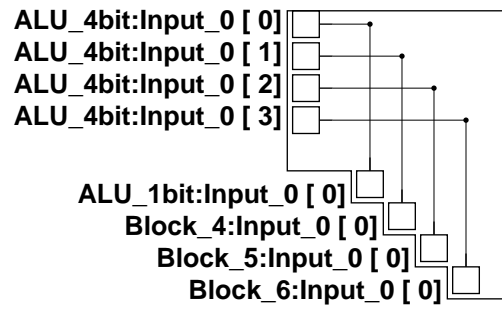

J_3 <Width 4>

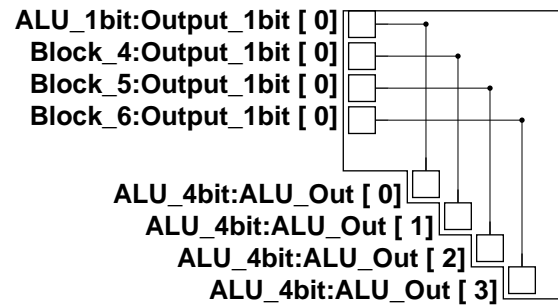

Designer :	Dr. James P. Davis	Date :	05 February 2003	Page No. :	9 of 14	
Design Name :	ALU_4_bit	Version :	v.02	Knowledge Based Silicon Corp.		

J_4 <Width 4>



Designer :	Dr. James P. Davis	Date :	05 February 2003	Page No. :	10 of 14	
Design Name :	ALU_4_bit	Version :	v.02	Knowledge Based Silicon Corp.		

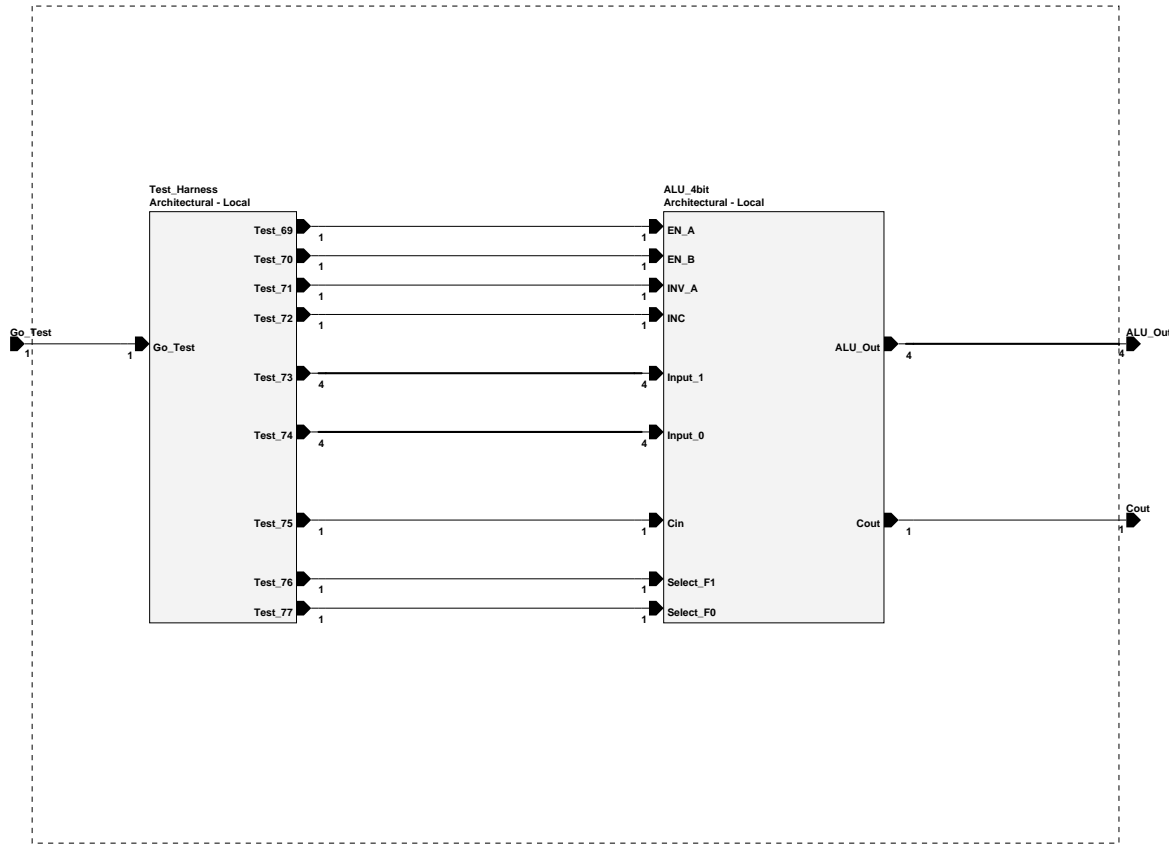

Designer :	Dr. James P. Davis	Date :	05 February 2003	Page No. :	11 of 14
Design Name :	ALU_4_bit	Version :	v.02	Knowledge Based Silicon Corp.	

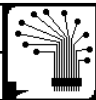

ALU_4bit

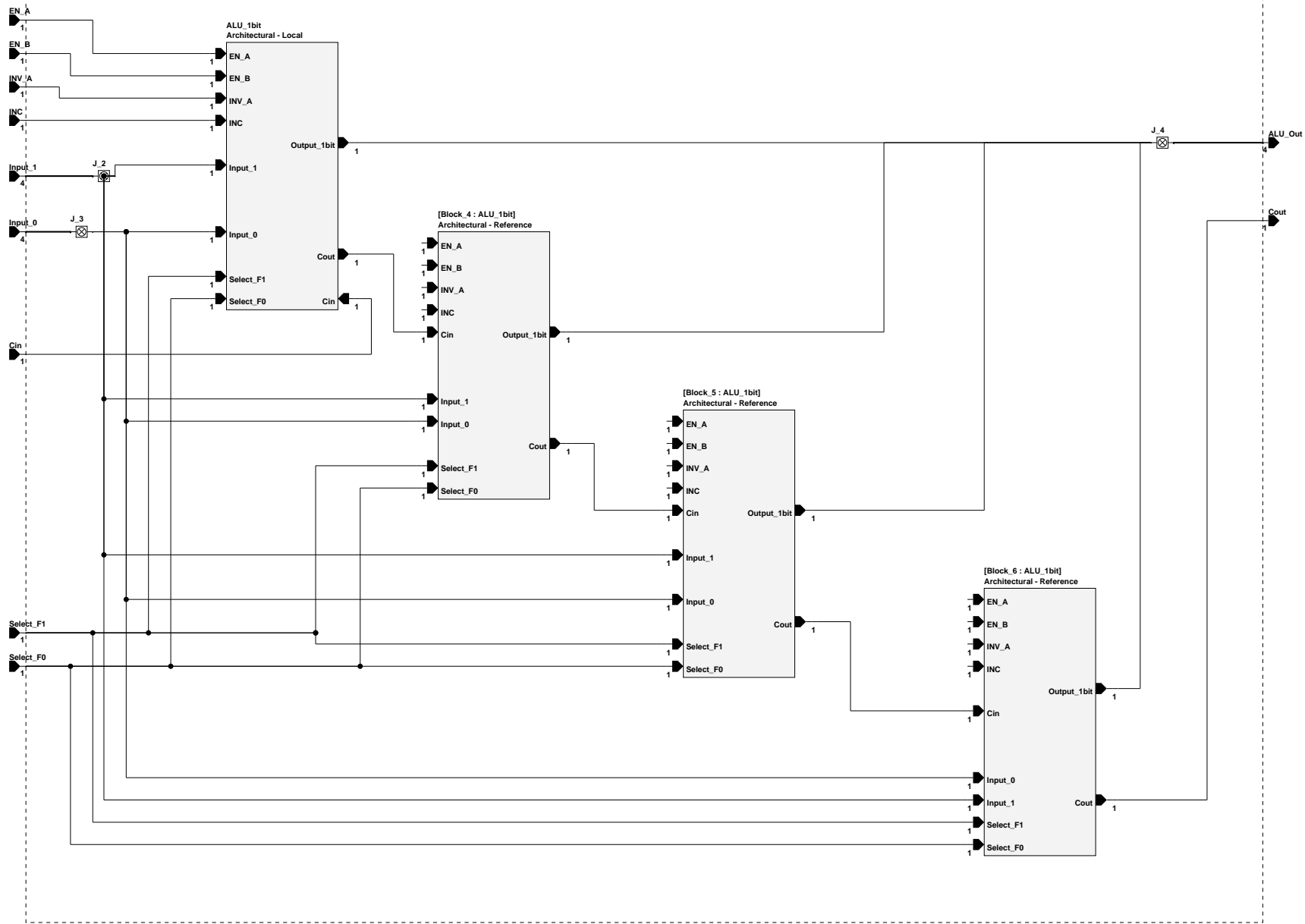

Designer :	Dr. James P. Davis	Date :	05 February 2003	Page No. :	12 of 14
Design Name :	ALU_4_bit	Version :	v.02	Knowledge Based Silicon Corp.	

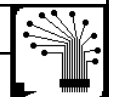

ALU_1bit

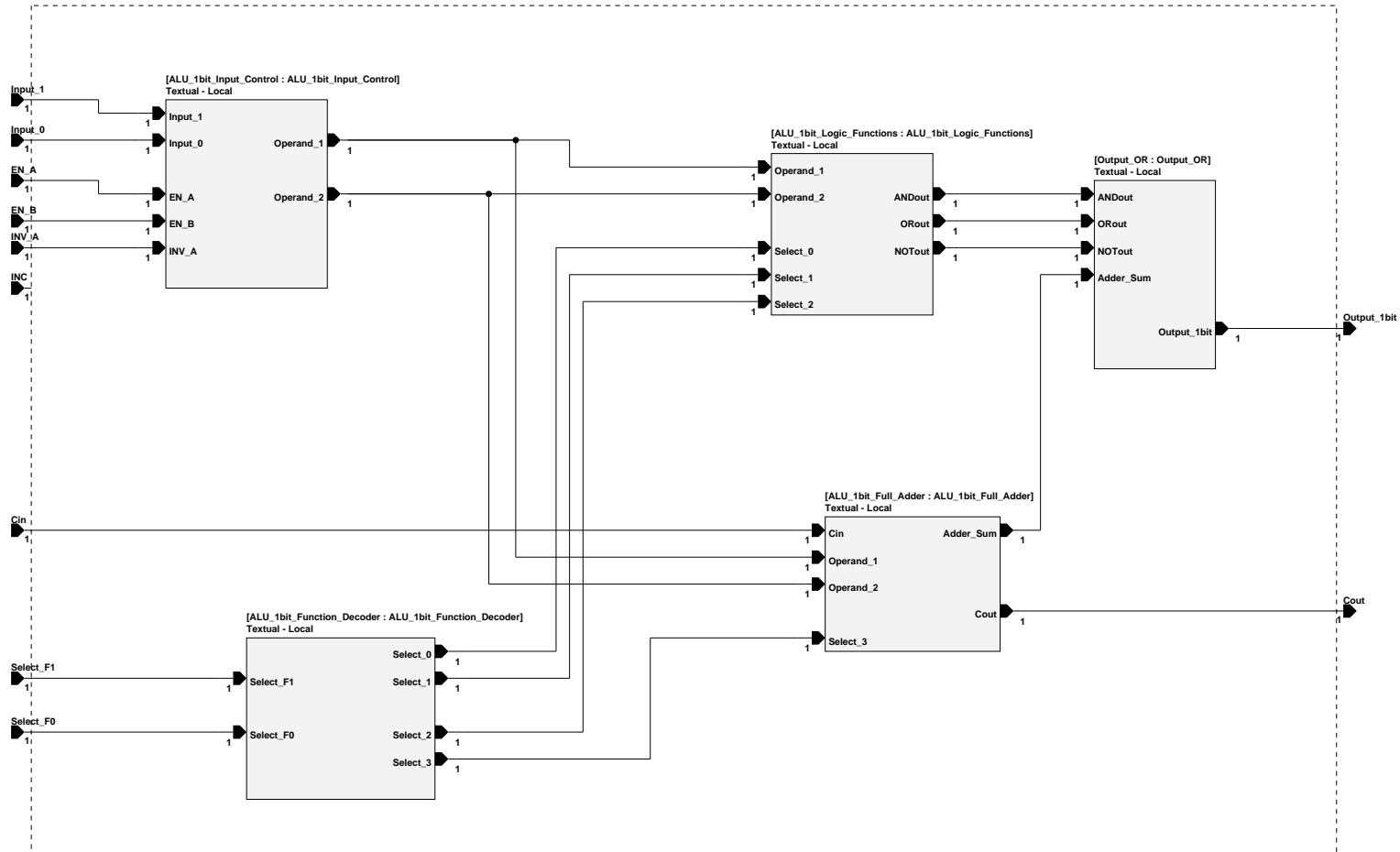

Designer :	Dr. James P. Davis	Date :	05 February 2003	Page No. :	13 of 14
Design Name :	ALU_4_bit	Version :	v.02	Knowledge Based Silicon Corp.	

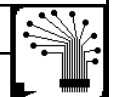

Test_Harness

Go Test

- Test.69
- Test.70
- Test.71
- Test.72
- Test.73
- Test.74
- Test.75
- Test.76
- Test.77

Designer : Dr. James P. Davis

Date : 05 February 2003

Page No. : 14 of 14

Design Name : ALU_4_bit

Version : v.02

Knowledge Based Silicon Corp.

