

**3-ANNEX A(informative)
DIAGRAMS**

Figure 3-A.1. Layer I and II decoder flow chart

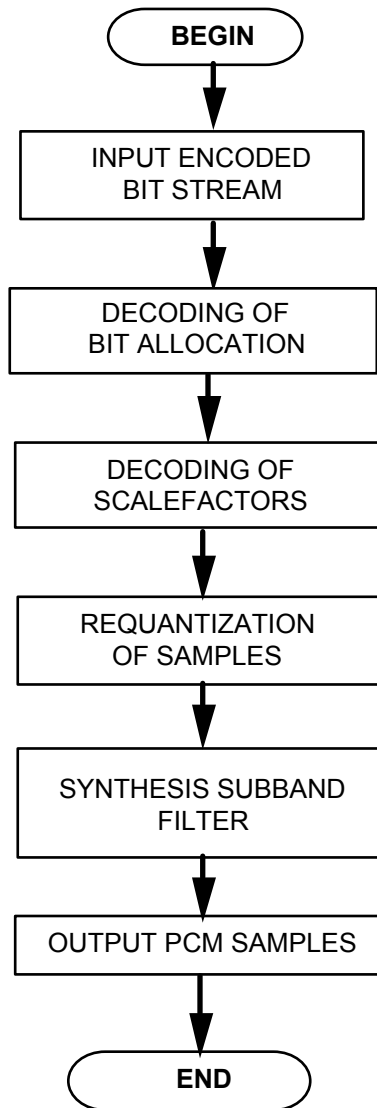

Figure 3-A.2. Synthesis subband filter flow chart

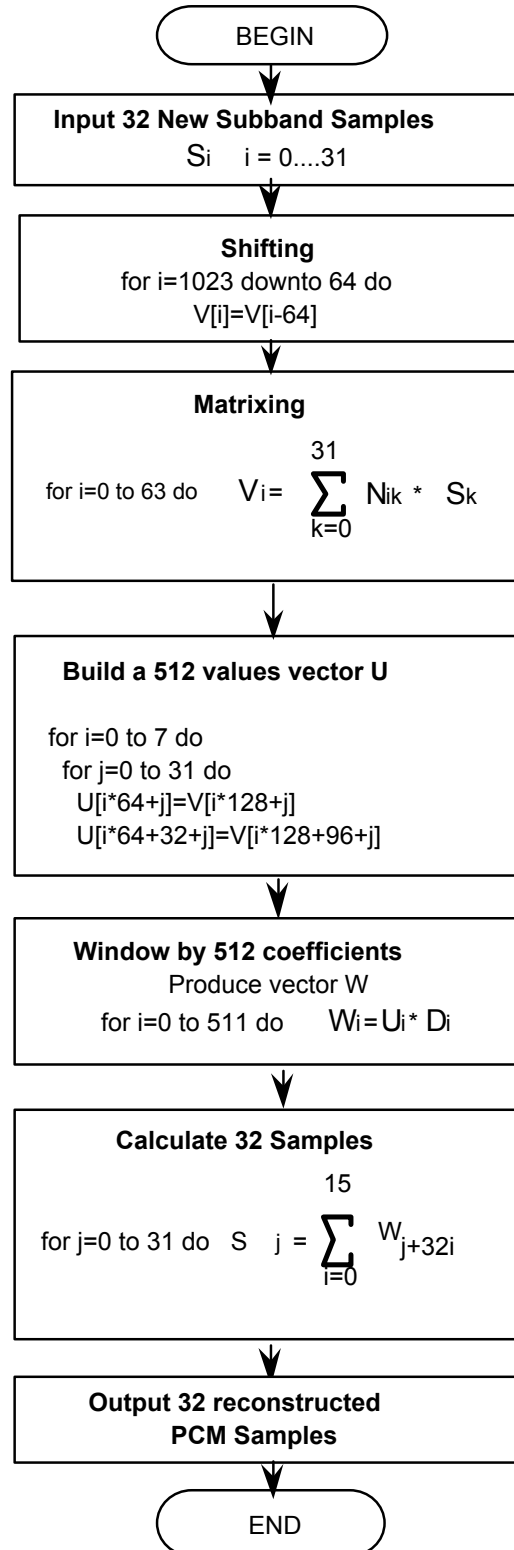

Figure 3-A.3. Layer III decoder flow chart

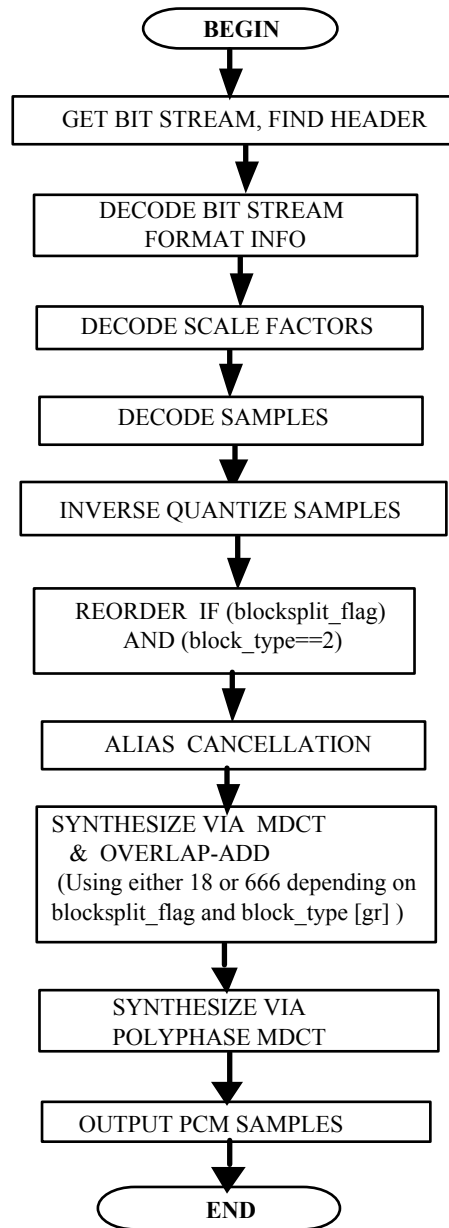
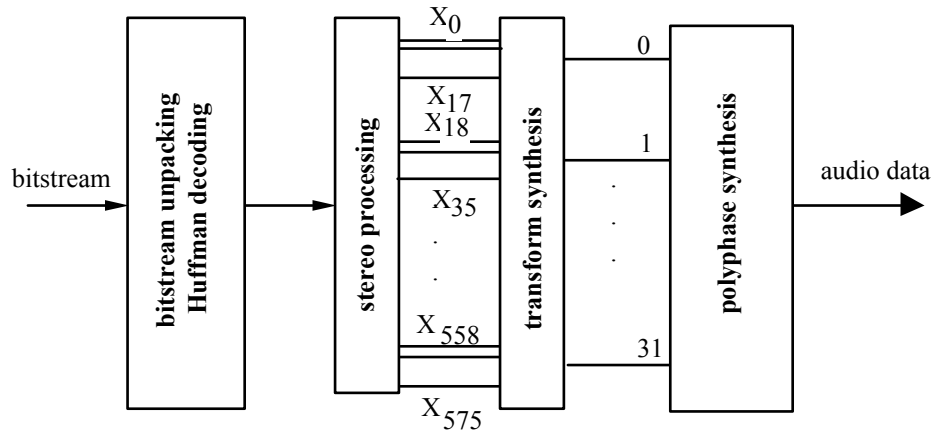

Figure 3-A.4. Layer III decoder diagram



Block "transform synthesis":

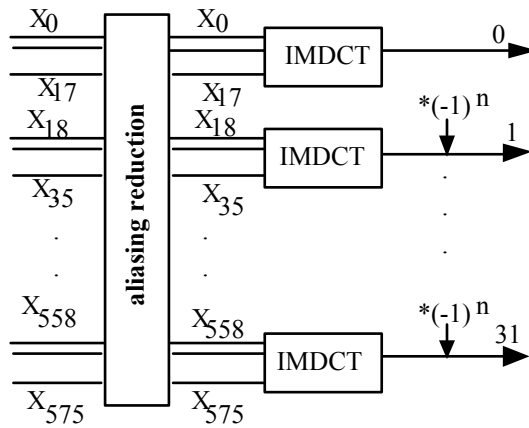

Figure 3-A.5. Layer III aliasing reduction encoder/decoder diagram

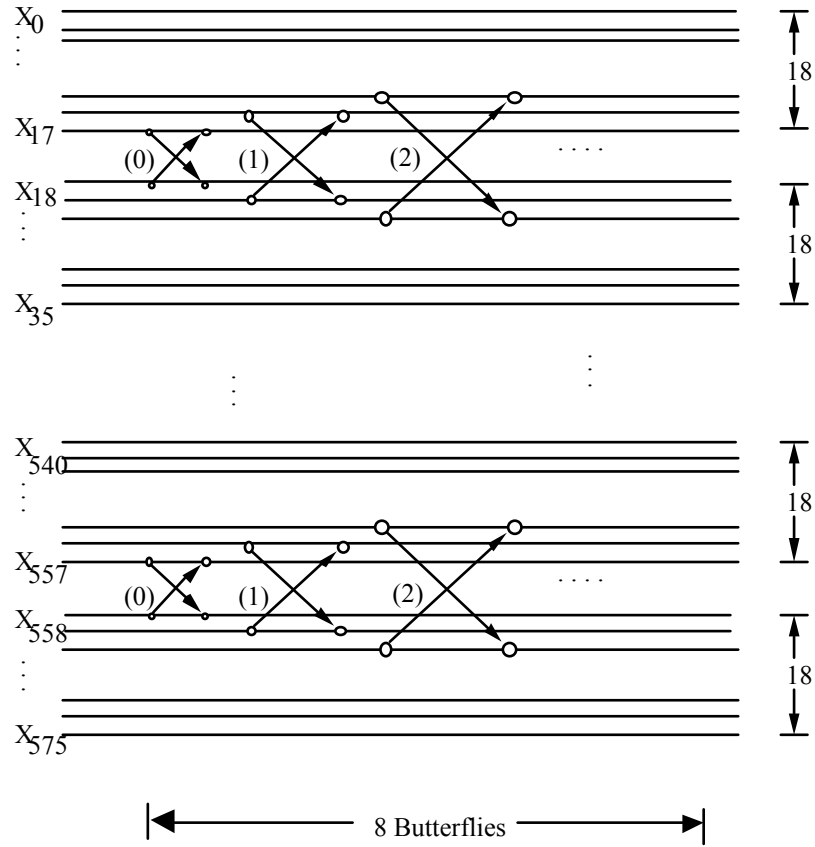

Figure 3-A.6. Layer III aliasing-butterfly, decoder

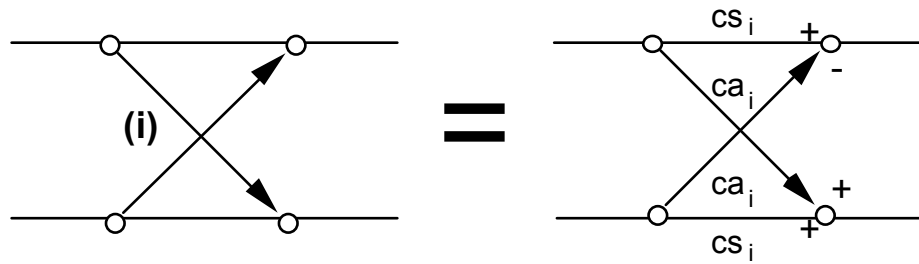

Figure 3-A.7.1. Layer III bitstream organization

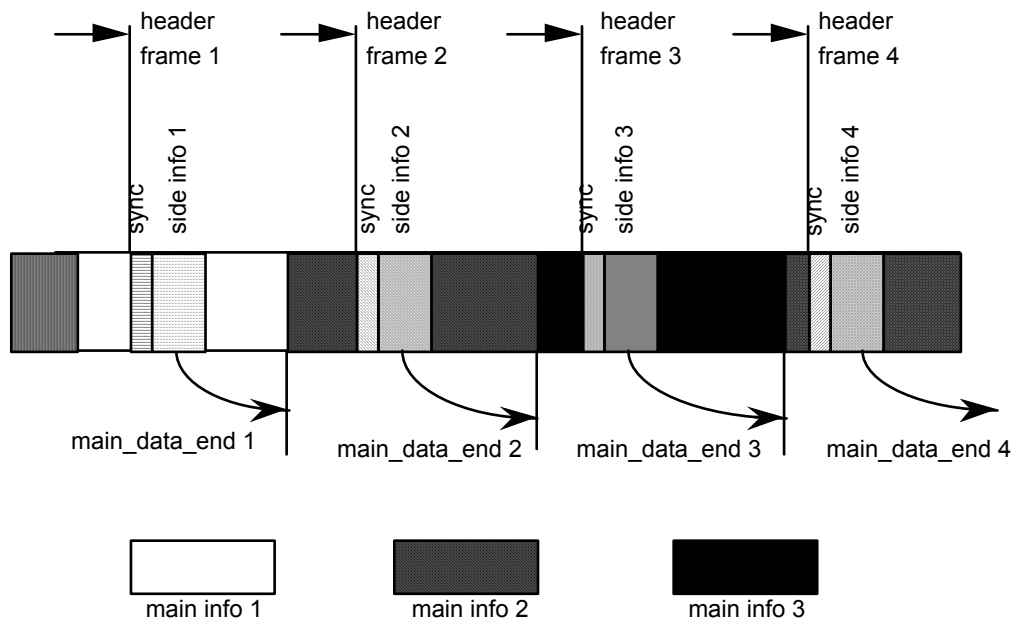
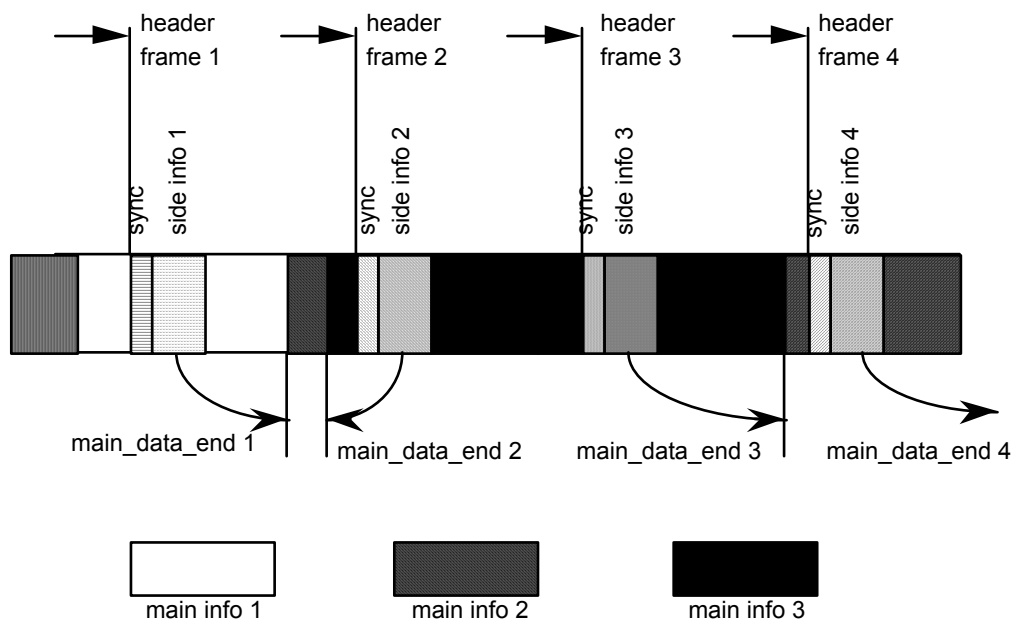

Figure 3-A.7.2. Layer III bitstream organization with peak demand at main info 3 and small demand at main info 2.



Note: 'info' means information

Figure 3-A.8. Layer III illustration of granules for frame with no block split in first granule and block split in second granule.

SB11 3 - 3 5 9 15 31 63 127
 SB12 0 -
 SB13 0 -
 SB14 0 -
 SB15 0 -
 SB16 0 -
 SB17 0 -
 SB18 0 -
 SB19 0 -
 SB20 0 -
 SB21 0 -
 SB22 0 -
 SB23 0 -
 SB24 0 -
 SB25 0 -
 SB26 0 -
 SB27 0 -
 SB28 0 -
 SB29 0 -
 SB30 0 -
 SB31 0 -

Max. No. of active subbands = 12
 Sum of nbal = 38

Table 3-B.3. Coefficients Di of the synthesis window

D[0]= 0.000000000	D[1]=-0.000015259	D[2]=-0.000015259	D[3]=-
0.000015259			
D[4]=-0.000015259	D[5]=-0.000015259	D[6]=-0.000015259	D[7]=-
0.000030518			
D[8]=-0.000030518	D[9]=-0.000030518	D[10]=-0.000030518	D[11]=-
0.000045776			
D[12]=-0.000045776	D[13]=-0.000061035	D[14]=-0.000061035	D[15]=-
0.000076294			
D[16]=-0.000076294	D[17]=-0.000091553	D[18]=-0.000106812	D[19]=-
0.000106812			
D[20]=-0.000122070	D[21]=-0.000137329	D[22]=-0.000152588	D[23]=-
0.000167847			
D[24]=-0.000198364	D[25]=-0.000213623	D[26]=-0.000244141	D[27]=-
0.000259399			
D[28]=-0.000289917	D[29]=-0.000320435	D[30]=-0.000366211	D[31]=-
0.000396729			
D[32]=-0.000442505	D[33]=-0.000473022	D[34]=-0.000534058	D[35]=-
0.000579834			
D[36]=-0.000625610	D[37]=-0.000686646	D[38]=-0.000747681	D[39]=-
0.000808716			
D[40]=-0.000885010	D[41]=-0.000961304	D[42]=-0.001037598	D[43]=-
0.001113892			
D[44]=-0.001205444	D[45]=-0.001296997	D[46]=-0.001388550	D[47]=-
0.001480103			
D[48]=-0.001586914	D[49]=-0.001693726	D[50]=-0.001785278	D[51]=-
0.001907349			
D[52]=-0.002014160	D[53]=-0.002120972	D[54]=-0.002243042	D[55]=-
0.002349854			
D[56]=-0.002456665	D[57]=-0.002578735	D[58]=-0.002685547	D[59]=-
0.002792358			
D[60]=-0.002899170	D[61]=-0.002990723	D[62]=-0.003082275	D[63]=-
0.003173828			
D[64]= 0.003250122	D[65]= 0.003326416	D[66]= 0.003387451	D[67]=
0.003433228			
D[68]= 0.003463745	D[69]= 0.003479004	D[70]= 0.003479004	D[71]=
0.003463745			
D[72]= 0.003417969	D[73]= 0.003372192	D[74]= 0.003280640	D[75]=
0.003173828			
D[76]= 0.003051758	D[77]= 0.002883911	D[78]= 0.002700806	D[79]=
0.002487183			

D[80]= 0.002227783	D[81]= 0.001937866	D[82]= 0.001617432	D[83]=
0.001266479			
D[84]= 0.000869751	D[85]= 0.000442505	D[86]=-0.000030518	D[87]=-
0.000549316			
D[88]=-0.001098633	D[89]=-0.001693726	D[90]=-0.002334595	D[91]=-
0.003005981			
D[92]=-0.003723145	D[93]=-0.004486084	D[94]=-0.005294800	D[95]=-
0.006118774			
D[96]=-0.007003784	D[97]=-0.007919312	D[98]=-0.008865356	D[99]=-
0.009841919			
D[100]=-0.010848999	D[101]=-0.011886597	D[102]=-0.012939453	D[103]=-
0.014022827			
D[104]=-0.015121460	D[105]=-0.016235352	D[106]=-0.017349243	D[107]=-
0.018463135			
D[108]=-0.019577026	D[109]=-0.020690918	D[110]=-0.021789551	D[111]=-
0.022857666			
D[112]=-0.023910522	D[113]=-0.024932861	D[114]=-0.025909424	D[115]=-
0.026840210			
D[116]=-0.027725220	D[117]=-0.028533936	D[118]=-0.029281616	D[119]=-
0.029937744			
D[120]=-0.030532837	D[121]=-0.031005859	D[122]=-0.031387329	D[123]=-
0.031661987			
D[124]=-0.031814575	D[125]=-0.031845093	D[126]=-0.031738281	D[127]=-
0.031478882			
D[128]= 0.031082153	D[129]= 0.030517578	D[130]= 0.029785156	D[131]=
0.028884888			
D[132]= 0.027801514	D[133]= 0.026535034	D[134]= 0.025085449	D[135]=
0.023422241			
D[136]= 0.021575928	D[137]= 0.019531250	D[138]= 0.017257690	D[139]=
0.014801025			
D[140]= 0.012115479	D[141]= 0.009231567	D[142]= 0.006134033	D[143]=
0.002822876			
D[144]=-0.000686646	D[145]=-0.004394531	D[146]=-0.008316040	D[147]=-
0.012420654			
D[148]=-0.016708374	D[149]=-0.021179199	D[150]=-0.025817871	D[151]=-
0.030609131			
D[152]=-0.035552979	D[153]=-0.040634155	D[154]=-0.045837402	D[155]=-
0.051132202			
D[156]=-0.056533813	D[157]=-0.061996460	D[158]=-0.067520142	D[159]=-
0.073059082			
D[160]=-0.078628540	D[161]=-0.084182739	D[162]=-0.089706421	D[163]=-
0.095169067			
D[164]=-0.100540161	D[165]=-0.105819702	D[166]=-0.110946655	D[167]=-
0.115921021			
D[168]=-0.120697021	D[169]=-0.125259399	D[170]=-0.129562378	D[171]=-
0.133590698			
D[172]=-0.137298584	D[173]=-0.140670776	D[174]=-0.143676758	D[175]=-
0.146255493			
D[176]=-0.148422241	D[177]=-0.150115967	D[178]=-0.151306152	D[179]=-
0.151962280			
D[180]=-0.152069092	D[181]=-0.151596069	D[182]=-0.150497437	D[183]=-
0.148773193			
D[184]=-0.146362305	D[185]=-0.143264771	D[186]=-0.139450073	D[187]=-
0.134887695			
D[188]=-0.129577637	D[189]=-0.123474121	D[190]=-0.116577148	D[191]=-
0.108856201			
D[192]= 0.100311279	D[193]= 0.090927124	D[194]= 0.080688477	D[195]=
0.069595337			
D[196]= 0.057617187	D[197]= 0.044784546	D[198]= 0.031082153	D[199]=
0.016510010			
D[200]= 0.001068115	D[201]=-0.015228271	D[202]=-0.032379150	D[203]=-
0.050354004			
D[204]=-0.069168091	D[205]=-0.088775635	D[206]=-0.109161377	D[207]=-
0.130310059			
D[208]=-0.152206421	D[209]=-0.174789429	D[210]=-0.198059082	D[211]=-
0.221984863			
D[212]=-0.246505737	D[213]=-0.271591187	D[214]=-0.297210693	D[215]=-
0.323318481			
D[216]=-0.349868774	D[217]=-0.376800537	D[218]=-0.404083252	D[219]=-
0.431655884			
D[220]=-0.459472656	D[221]=-0.487472534	D[222]=-0.515609741	D[223]=-
0.543823242			
D[224]=-0.572036743	D[225]=-0.600219727	D[226]=-0.628295898	D[227]=-
0.656219482			
D[228]=-0.683914185	D[229]=-0.711318970	D[230]=-0.738372803	D[231]=-
0.765029907			
D[232]=-0.791213989	D[233]=-0.816864014	D[234]=-0.841949463	D[235]=-
0.866363525			
D[236]=-0.890090942	D[237]=-0.913055420	D[238]=-0.935195923	D[239]=-
0.956481934			

D[240]=-0.976852417	D[241]=-0.996246338	D[242]=-1.014617920	D[243]=-
1.031936646			
D[244]=-1.048156738	D[245]=-1.063217163	D[246]=-1.077117920	D[247]=-
1.089782715			
D[248]=-1.101211548	D[249]=-1.111373901	D[250]=-1.120223999	D[251]=-
1.127746582			
D[252]=-1.133926392	D[253]=-1.138763428	D[254]=-1.142211914	D[255]=-
1.144287109			
D[256]= 1.144989014	D[257]= 1.144287109	D[258]= 1.142211914	D[259]=
1.138763428			
D[260]= 1.133926392	D[261]= 1.127746582	D[262]= 1.120223999	D[263]=
1.111373901			
D[264]= 1.101211548	D[265]= 1.089782715	D[266]= 1.077117920	D[267]=
1.063217163			
D[268]= 1.048156738	D[269]= 1.031936646	D[270]= 1.014617920	D[271]=
0.996246338			
D[272]= 0.976852417	D[273]= 0.956481934	D[274]= 0.935195923	D[275]=
0.913055420			
D[276]= 0.890090942	D[277]= 0.866363525	D[278]= 0.841949463	D[279]=
0.816864014			
D[280]= 0.791213989	D[281]= 0.765029907	D[282]= 0.738372803	D[283]=
0.711318970			
D[284]= 0.683914185	D[285]= 0.656219482	D[286]= 0.628295898	D[287]=
0.600219727			
D[288]= 0.572036743	D[289]= 0.543823242	D[290]= 0.515609741	D[291]=
0.487472534			
D[292]= 0.459472656	D[293]= 0.431655884	D[294]= 0.404083252	D[295]=
0.376800537			
D[296]= 0.349868774	D[297]= 0.323318481	D[298]= 0.297210693	D[299]=
0.271591187			
D[300]= 0.246505737	D[301]= 0.221984863	D[302]= 0.198059082	D[303]=
0.174789429			
D[304]= 0.152206421	D[305]= 0.130310059	D[306]= 0.109161377	D[307]=
0.088775635			
D[308]= 0.069168091	D[309]= 0.050354004	D[310]= 0.032379150	D[311]=
0.015228271			
D[312]=-0.001068115	D[313]=-0.016510010	D[314]=-0.031082153	D[315]=-
0.044784546			
D[316]=-0.057617187	D[317]=-0.069595337	D[318]=-0.080688477	D[319]=-
0.090927124			
D[320]= 0.100311279	D[321]= 0.108856201	D[322]= 0.116577148	D[323]=
0.123474121			
D[324]= 0.129577637	D[325]= 0.134887695	D[326]= 0.139450073	D[327]=
0.143264771			
D[328]= 0.146362305	D[329]= 0.148773193	D[330]= 0.150497437	D[331]=
0.151596069			
D[332]= 0.152069092	D[333]= 0.151962280	D[334]= 0.151306152	D[335]=
0.150115967			
D[336]= 0.148422241	D[337]= 0.146255493	D[338]= 0.143676758	D[339]=
0.140670776			
D[340]= 0.137298584	D[341]= 0.133590698	D[342]= 0.129562378	D[343]=
0.125259399			
D[344]= 0.120697021	D[345]= 0.115921021	D[346]= 0.110946655	D[347]=
0.105819702			
D[348]= 0.100540161	D[349]= 0.095169067	D[350]= 0.089706421	D[351]=
0.084182739			
D[352]= 0.078628540	D[353]= 0.073059082	D[354]= 0.067520142	D[355]=
0.061996460			
D[356]= 0.056533813	D[357]= 0.051132202	D[358]= 0.045837402	D[359]=
0.040634155			
D[360]= 0.035552979	D[361]= 0.030609131	D[362]= 0.025817871	D[363]=
0.021179199			
D[364]= 0.016708374	D[365]= 0.012420654	D[366]= 0.008316040	D[367]=
0.004394531			
D[368]= 0.000686646	D[369]=-0.002822876	D[370]=-0.006134033	D[371]=-
0.009231567			
D[372]=-0.012115479	D[373]=-0.014801025	D[374]=-0.017257690	D[375]=-
0.019531250			
D[376]=-0.021575928	D[377]=-0.023422241	D[378]=-0.025085449	D[379]=-
0.026535034			
D[380]=-0.027801514	D[381]=-0.028884888	D[382]=-0.029785156	D[383]=-
0.030517578			
D[384]= 0.031082153	D[385]= 0.031478882	D[386]= 0.031738281	D[387]=
0.031845093			
D[388]= 0.031814575	D[389]= 0.031661987	D[390]= 0.031387329	D[391]=
0.031005859			
D[392]= 0.030532837	D[393]= 0.029937744	D[394]= 0.029281616	D[395]=
0.028533936			
D[396]= 0.027725220	D[397]= 0.026840210	D[398]= 0.025909424	D[399]=
0.024932861			

D[400]= 0.023910522	D[401]= 0.022857666	D[402]= 0.021789551	D[403]=
0.020690918			
D[404]= 0.019577026	D[405]= 0.018463135	D[406]= 0.017349243	D[407]=
0.016235352			
D[408]= 0.015121460	D[409]= 0.014022827	D[410]= 0.012939453	D[411]=
0.011886597			
D[412]= 0.010848999	D[413]= 0.009841919	D[414]= 0.008865356	D[415]=
0.007919312			
D[416]= 0.007003784	D[417]= 0.006118774	D[418]= 0.005294800	D[419]=
0.004486084			
D[420]= 0.003723145	D[421]= 0.003005981	D[422]= 0.002334595	D[423]=
0.001693726			
D[424]= 0.001098633	D[425]= 0.000549316	D[426]= 0.000030518	D[427]=-
0.000442505			
D[428]=-0.000869751	D[429]=-0.001266479	D[430]=-0.001617432	D[431]=-
0.001937866			
D[432]=-0.002227783	D[433]=-0.002487183	D[434]=-0.002700806	D[435]=-
0.002883911			
D[436]=-0.003051758	D[437]=-0.003173828	D[438]=-0.003280640	D[439]=-
0.003372192			
D[440]=-0.003417969	D[441]=-0.003463745	D[442]=-0.003479004	D[443]=-
0.003479004			
D[444]=-0.003463745	D[445]=-0.003433228	D[446]=-0.003387451	D[447]=-
0.003326416			
D[448]= 0.003250122	D[449]= 0.003173828	D[450]= 0.003082275	D[451]=
0.002990723			
D[452]= 0.002899170	D[453]= 0.002792358	D[454]= 0.002685547	D[455]=
0.002578735			
D[456]= 0.002456665	D[457]= 0.002349854	D[458]= 0.002243042	D[459]=
0.002120972			
D[460]= 0.002014160	D[461]= 0.001907349	D[462]= 0.001785278	D[463]=
0.001693726			
D[464]= 0.001586914	D[465]= 0.001480103	D[466]= 0.001388550	D[467]=
0.001296997			
D[468]= 0.001205444	D[469]= 0.001113892	D[470]= 0.001037598	D[471]=
0.000961304			
D[472]= 0.0008885010	D[473]= 0.000808716	D[474]= 0.000747681	D[475]=
0.000686646			
D[476]= 0.000625610	D[477]= 0.000579834	D[478]= 0.000534058	D[479]=
0.000473022			
D[480]= 0.000442505	D[481]= 0.000396729	D[482]= 0.000366211	D[483]=
0.000320435			
D[484]= 0.000289917	D[485]= 0.000259399	D[486]= 0.000244141	D[487]=
0.000213623			
D[488]= 0.000198364	D[489]= 0.000167847	D[490]= 0.000152588	D[491]=
0.000137329			
D[492]= 0.000122070	D[493]= 0.000106812	D[494]= 0.000106812	D[495]=
0.000091553			
D[496]= 0.000076294	D[497]= 0.000076294	D[498]= 0.000061035	D[499]=
0.000061035			
D[500]= 0.000045776	D[501]= 0.000045776	D[502]= 0.000030518	D[503]=
0.000030518			
D[504]= 0.000030518	D[505]= 0.000030518	D[506]= 0.000015259	D[507]=
0.000015259			
D[508]= 0.000015259	D[509]= 0.000015259	D[510]= 0.000015259	D[511]=
0.000015259			

Table 3-B.4. Layer II classes of quantization

NumberC of steps	D	grouping	Samples per codeword	Bits per codeword
3	1.3333333333	0.5000000000	yes	3
5	1.6000000000	0.5000000000	yes	7
7	1.14285714286	0.2500000000	no	3
9	1.7777777777	0.5000000000	yes	10
15	1.0666666666	0.1250000000	no	4
31	1.03225806452	0.0625000000	no	5
63	1.01587301587	0.0312500000	no	6
127	1.00787401575	0.0156250000	no	7
255	1.00392156863	0.0078125000	no	8
511	1.00195694716	0.0039062500	no	9
1023	1.00097751711	0.0019531250	no	10
2047	1.00048851979	0.0009765625	no	11

4095	1.00024420024	0.00048828125	no	1	12
8191	1.00012208522	0.00024414063	no	1	13
16383	1.00006103888	0.00012207031	no	1	14
32767	1.00003051851	0.00006103516	no	1	15
65535	1.00001525902	0.00003051758	no	1	16

Table 3-B.5. Number of protected audio_data bits

Layer	bit alloc. table	no. of bits single channel mode	no. of bits other modes
I	-	128	256
II	3-B.2a	142	284
II	3-B.2b	154	308
II	3-B.2c	42	84
II	3-B.2d	62	124
III	-	136	256

Table 3-B.6. Layer III Preemphasis

000000000001111223332

Table 3-B.7. Huffman codes for Layer III

Huffman code table for quadruples (A)

Value	hlen	hcod
0000	1	1
0001	4	0101
0010	4	0100
0011	5	00101
0100	4	0110
0101	6	000101
0110	5	00100
0111	6	000100
1000	4	0111
1001	5	00011
1010	5	00110
1011	6	000000
1100	5	00111
1101	6	000010
1110	6	000011
1111	6	000001

Huffman code table for quadruples (B)

Value	hlen	hcod
0000	4	1111
0001	4	1110
0010	4	1101
0011	4	1100
0100	4	1011
0101	4	1010
0110	4	1001
0111	4	1000
1000	4	0111
1001	4	0110
1010	4	0101
1011	4	0100
1100	4	0011
1101	4	0010
1110	4	0001
1111	4	0000

Huffman code table 0

```
x y hlen
0 0 0
```

Huffman code table 1

```
x y hlen hcod
0 0 1 1
0 1 3 001
1 0 2 01
1 1 3 000
```

Huffman code table 2

```
x y hlen hcod
0 0 1 1
0 1 3 010
0 2 6 000001
1 0 3 011
1 1 3 001
1 2 5 00001
2 0 5 00011
2 1 5 00010
2 2 6 000000
```

Huffman code table 3

```
x y hlen hcod
0 0 2 11
0 1 2 10
0 2 6 000001
1 0 3 001
1 1 2 01
1 2 5 00001
2 0 5 00011
2 1 5 00010
2 2 6 000000
```

Huffman code table 4

not used

Huffman code table 5

```
x y hlen hcod
0 0 1 1
0 1 3 010
0 2 6 000110
0 3 7 0000101
1 0 3 011
1 1 3 001
1 2 6 000100
1 3 7 0000100
2 0 6 000111
2 1 6 000101
2 2 7 0000111
2 3 8 00000001
3 0 7 0000110
3 1 6 000001
3 2 7 0000001
3 3 8 00000000
```

Huffman code table 6

```
x y hlen hcod
0 0 3 111
0 1 3 011
0 2 5 00101
0 3 7 0000001
1 0 3 110
1 1 2 10
1 2 4 0011
1 3 5 00010
2 0 4 0101
2 1 4 0100
2 2 5 00100
2 3 6 000001
3 0 6 000011
```

```

3 1 5 00011
3 2 6 000010
3 3 7 0000000

```

Huffman code table 7

```

x y hlen hcod
0 0 1 1
0 1 3 010
0 2 6 001010
0 3 8 00010011
0 4 8 00010000
0 5 9 000001010
1 0 3 011
1 1 4 0011
1 2 6 000111
1 3 7 0001010
1 4 7 0000101
1 5 8 00000011
2 0 6 001011
2 1 5 00100
2 2 7 0001101
2 3 8 00010001
2 4 8 00001000
2 5 9 000000100
3 0 7 0001100
3 1 7 0001011
3 2 8 00010010
3 3 9 000001111
3 4 9 000001011
3 5 9 000000010
4 0 7 0000111
4 1 7 0000110
4 2 8 00001001
4 3 9 000001110
4 4 9 000000011
4 5 10 0000000001
5 0 8 00000110
5 1 8 00000100
5 2 9 000000101
5 3 10 0000000011
5 4 10 0000000010
5 5 10 0000000000

```

Huffman code table 8

```

x y hlen hcod
0 0 2 11
0 1 3 100
0 2 6 000110
0 3 8 00010010
0 4 8 00001100
0 5 9 000000101
1 0 3 101
1 1 2 01
1 2 4 0010
1 3 8 00010000
1 4 8 00001001
1 5 8 00000011
2 0 6 000111
2 1 4 0011
2 2 6 000101
2 3 8 00001110
2 4 8 00000111
2 5 9 000000011
3 0 8 00010011
3 1 8 00010001
3 2 8 00001111
3 3 9 000001101
3 4 9 000001010
3 5 10 0000000100
4 0 8 00001101
4 1 7 0000101
4 2 8 00001000
4 3 9 000001011
4 4 10 0000000101
4 5 10 0000000001
5 0 9 000001100
5 1 8 00000100
5 2 9 000000100

```

```

5 3 9 000000001
5 4 11 00000000001
5 5 11 00000000000

```

Huffman code table 9

```

x y hlen hcod
0 0 3 111
0 1 3 101
0 2 5 01001
0 3 6 001110
0 4 8 00001111
0 5 9 000000111
1 0 3 110
1 1 3 100
1 2 4 0101
1 3 5 00101
1 4 6 000110
1 5 8 00000111
2 0 4 0111
2 1 4 0110
2 2 5 01000
2 3 6 001000
2 4 7 0001000
2 5 8 00000101
3 0 6 001111
3 1 5 00110
3 2 6 001001
3 3 7 0001010
3 4 7 0000101
3 5 8 00000001
4 0 7 0001011
4 1 6 000111
4 2 7 0001001
4 3 7 0000110
4 4 8 00000100
4 5 9 000000001
5 0 8 00001110
5 1 7 0000100
5 2 8 00000110
5 3 8 00000010
5 4 9 000000110
5 5 9 000000000

```

Huffman code table 10

```

x y hlen hcod
0 0 1 1
0 1 3 010
0 2 6 001010
0 3 8 00010111
0 4 9 000100011
0 5 9 000011110
0 6 9 000001100
0 7 10 0000010001
1 0 3 011
1 1 4 0011
1 2 6 001000
1 3 7 0001100
1 4 8 00010010
1 5 9 000010101
1 6 8 00001100
1 7 8 00000111
2 0 6 001011
2 1 6 001001
2 2 7 0001111
2 3 8 00010101
2 4 9 000100000
2 5 10 0000101000
2 6 9 000010011
2 7 9 000000110
3 0 7 0001110
3 1 7 0001101
3 2 8 00010110
3 3 9 000100010
3 4 10 0000101110
3 5 10 0000010111
3 6 9 000010010
3 7 10 0000000111
4 0 8 00010100

```

4	1	8	00010011
4	2	9	000100001
4	3	10	0000101111
4	4	10	0000011011
4	5	10	0000010110
4	6	10	0000001001
4	7	10	0000000011
5	0	9	000011111
5	1	9	000010110
5	2	10	0000101001
5	3	10	0000011010
5	4	11	00000010101
5	5	11	00000010100
5	6	10	0000000101
5	7	11	00000000011
6	0	8	00001110
6	1	8	00001101
6	2	9	000001010
6	3	10	0000001011
6	4	10	0000010000
6	5	10	0000000110
6	6	11	00000000101
6	7	11	00000000001
7	0	9	000001001
7	1	8	00001000
7	2	9	000000111
7	3	10	0000001000
7	4	10	0000000100
7	5	11	00000000100
7	6	11	00000000010
7	7	11	00000000000

Huffman code table 11

x	y	hlen	hcod
0	0	2	11
0	1	3	100
0	2	5	01010
0	3	7	0011000
0	4	8	00100010
0	5	9	000100001
0	6	8	00010101
0	7	9	000001111
1	0	3	101
1	1	3	011
1	2	4	0100
1	3	6	001010
1	4	8	00100000
1	5	8	00010001
1	6	7	0001011
1	7	8	00001010
2	0	5	01011
2	1	5	00111
2	2	6	001101
2	3	7	0010010
2	4	8	00011110
2	5	9	000011111
2	6	8	00010100
2	7	8	00000101
3	0	7	0011001
3	1	6	001011
3	2	7	0010011
3	3	9	000111011
3	4	8	00011011
3	5	10	0000010010
3	6	8	00001100
3	7	9	000000101
4	0	8	00100011
4	1	8	00100001
4	2	8	00011111
4	3	9	000111010
4	4	9	000011110
4	5	10	0000010000
4	6	9	000000111
4	7	10	0000000101
5	0	8	00011100
5	1	8	00011010
5	2	9	000100000
5	3	10	0000010011
5	4	10	0000010001

```

5 5 11 00000001111
5 6 10 0000001000
5 7 11 00000001110
6 0 8 00001110
6 1 7 0001100
6 2 7 0001001
6 3 8 00001101
6 4 9 000001110
6 5 10 0000001001
6 6 10 0000000100
6 7 10 0000000001
7 0 8 00001011
7 1 7 0000100
7 2 8 00000110
7 3 9 000000110
7 4 10 0000000110
7 5 10 0000000011
7 6 10 0000000010
7 7 10 0000000000

```

Huffman code table 12

```

x y hlen hcod
0 0 4 1001
0 1 3 110
0 2 5 10000
0 3 7 0100001
0 4 8 00101001
0 5 9 000100111
0 6 9 000100110
0 7 9 000011010
1 0 3 111
1 1 3 101
1 2 4 0110
1 3 5 01001
1 4 7 0010111
1 5 7 0010000
1 6 8 00011010
1 7 8 00001011
2 0 5 10001
2 1 4 0111
2 2 5 01011
2 3 6 001110
2 4 7 0010101
2 5 8 00011110
2 6 7 0001010
2 7 8 00000111
3 0 6 010001
3 1 5 01010
3 2 6 001111
3 3 6 001100
3 4 7 0010010
3 5 8 00011100
3 6 8 00001110
3 7 8 00000101
4 0 7 0100000
4 1 6 001101
4 2 7 0010110
4 3 7 0010011
4 4 8 00010010
4 5 8 00010000
4 6 8 00001001
4 7 9 000000101
5 0 8 00101000
5 1 7 0010001
5 2 8 00011111
5 3 8 00011101
5 4 8 00010001
5 5 9 000001101
5 6 8 00000100
5 7 9 000000010
6 0 8 00011011
6 1 7 0001100
6 2 7 0001011
6 3 8 00001111
6 4 8 00001010
6 5 9 000000111
6 6 9 000000100
6 7 10 0000000001
7 0 9 000011011

```

7	1	8	00001100
7	2	8	00001000
7	3	9	000001100
7	4	9	000000110
7	5	9	000000011
7	6	9	000000001
7	7	10	0000000000

Huffman code table 13

x	y	hlen	hcod
0	0	1	1
0	1	4	0101
0	2	6	001110
0	3	7	0010101
0	4	8	00100010
0	5	9	000110011
0	6	9	000101110
0	7	10	0001000111
0	8	9	000101010
0	9	10	0000110100
0	10	11	00001000100
0	11	11	00000110100
0	12	12	000001000011
0	13	12	000000101100
0	14	13	0000000101011
0	15	13	0000000010011
1	0	3	011
1	1	4	0100
1	2	6	001100
1	3	7	0010011
1	4	8	00011111
1	5	8	00011010
1	6	9	000101100
1	7	9	000100001
1	8	9	000011111
1	9	9	000011000
1	10	10	0000100000
1	11	10	0000011000
1	12	11	00000011111
1	13	12	000000100011
1	14	12	000000010110
1	15	12	000000001110
2	0	6	001111
2	1	6	001101
2	2	7	0010111
2	3	8	00100100
2	4	9	000111011
2	5	9	000110001
2	6	10	0001001101
2	7	10	0001000001
2	8	9	000011101
2	9	10	0000101000
2	10	10	0000011110
2	11	11	00000101000
2	12	11	00000011011
2	13	12	000000100001
2	14	13	0000000101010
2	15	13	0000000010000
3	0	7	0010110
3	1	7	0010100
3	2	8	00100101
3	3	9	000111101
3	4	9	000111000
3	5	10	0001001111
3	6	10	0001001001
3	7	10	0001000000
3	8	10	0000101011
3	9	11	00001001100
3	10	11	00000111000
3	11	11	00000100101
3	12	11	00000011010
3	13	12	000000011111
3	14	13	0000000011001
3	15	13	0000000001110
4	0	8	00100011
4	1	7	0010000
4	2	9	000111100
4	3	9	000111001
4	4	10	0001100001

```
4 5 10 0001001011
4 6 11 00001110010
4 7 11 00001011011
4 8 10 0000110110
4 9 11 00001001001
4 10 11 00000110111
4 11 12 000000101001
4 12 12 000000110000
4 13 13 0000000110101
4 14 13 0000000010111
4 15 14 00000000011000
5 0 9 000111010
5 1 8 00011011
5 2 9 000110010
5 3 10 0001100000
5 4 10 0001001100
5 5 10 0001000110
5 6 11 00001011101
5 7 11 00001010100
5 8 11 00001001101
5 9 11 00000111010
5 10 12 000001001111
5 11 11 00000011101
5 12 13 0000001001010
5 13 13 0000000110001
5 14 14 00000000101001
5 15 14 00000000010001
6 0 9 000101111
6 1 9 000101101
6 2 10 0001001110
6 3 10 0001001010
6 4 11 00001110011
6 5 11 00001011110
6 6 11 00001011010
6 7 11 00001001111
6 8 11 00001000101
6 9 12 000001010011
6 10 12 000001000111
6 11 12 000000110010
6 12 13 0000000111011
6 13 13 0000000100110
6 14 14 00000000100100
6 15 14 00000000001111
7 0 10 0001001000
7 1 9 000100010
7 2 10 0000111000
7 3 11 00001011111
7 4 11 00001011100
7 5 11 00001010101
7 6 12 000001011011
7 7 12 000001011010
7 8 12 000001010110
7 9 12 000001001001
7 10 13 0000001001101
7 11 13 0000001000001
7 12 13 0000000110011
7 13 14 00000000101100
7 14 16 0000000000101011
7 15 16 0000000000101010
8 0 9 000101011
8 1 8 00010100
8 2 9 000011110
8 3 10 0000101100
8 4 10 0000110111
8 5 11 00001001110
8 6 11 00001001000
8 7 12 000001010111
8 8 12 000001001110
8 9 12 000000111101
8 10 12 000000101110
8 11 13 0000000110110
8 12 13 0000000100101
8 13 14 00000000011110
8 14 15 000000000010100
8 15 15 000000000010000
9 0 10 0000110101
9 1 9 000011001
9 2 10 0000101001
9 3 10 0000100101
9 4 11 00000101100
9 5 11 00000111011
```

9 6 11 00000110110
9 7 13 0000001010001
9 8 12 000001000010
9 9 13 0000001001100
9 10 13 0000000111001
9 11 14 00000000110110
9 12 14 00000000100101
9 13 14 00000000010010
9 14 16 0000000000100111
9 15 15 000000000001011
10 0 10 0000100011
10 1 10 0000100001
10 2 10 0000011111
10 3 11 00000111001
10 4 11 00000101010
10 5 12 000001010010
10 6 12 000001001000
10 7 13 0000001010000
10 8 12 000000101111
10 9 13 0000000111010
10 10 14 00000000110111
10 11 13 0000000010101
10 12 14 00000000010110
10 13 15 000000000011010
10 14 16 0000000000100110
10 15 17 00000000000010110
11 0 11 00000110101
11 1 10 0000011001
11 2 10 0000010111
11 3 11 00000100110
11 4 12 000001000110
11 5 12 000000111100
11 6 12 000000110011
11 7 12 000000100100
11 8 13 0000000110111
11 9 13 0000000011010
11 10 13 0000000100010
11 11 14 00000000010111
11 12 15 000000000011011
11 13 15 000000000001110
11 14 15 000000000001001
11 15 16 0000000000000111
12 0 11 00000100010
12 1 11 00000100000
12 2 11 00000011100
12 3 12 000000100111
12 4 12 000000110001
12 5 13 0000001001011
12 6 12 000000011110
12 7 13 0000000110100
12 8 14 00000000110000
12 9 14 00000000101000
12 10 15 000000000110100
12 11 15 000000000011100
12 12 15 000000000010010
12 13 16 0000000000010001
12 14 16 0000000000001001
12 15 16 0000000000000101
13 0 12 000000101101
13 1 11 00000010101
13 2 12 000000100010
13 3 13 0000001000000
13 4 13 0000000111000
13 5 13 0000000110010
13 6 14 00000000110001
13 7 14 00000000101101
13 8 14 00000000011111
13 9 14 00000000010011
13 10 14 00000000001100
13 11 15 000000000001111
13 12 16 0000000000001010
13 13 15 000000000000111
13 14 16 0000000000000110
13 15 16 0000000000000011
14 0 13 0000000110000
14 1 12 000000010111
14 2 12 000000010100
14 3 13 0000000100111
14 4 13 0000000100100
14 5 13 0000000100011
14 6 15 00000000110101

```

14 7 14 00000000010101
14 8 14 00000000010000
14 9 17 00000000000010111
14 10 15 000000000001101
14 11 15 000000000001010
14 12 15 000000000000110
14 13 17 00000000000000001
14 14 16 0000000000000100
14 15 16 0000000000000010
15 0 12 000000010000
15 1 12 000000011111
15 2 13 000000010001
15 3 14 00000000011011
15 4 14 0000000011001
15 5 14 00000000010100
15 6 15 000000000011101
15 7 14 00000000001011
15 8 15 000000000010001
15 9 15 000000000001100
15 10 16 0000000000010000
15 11 16 0000000000001000
15 12 19 0000000000000000001
15 13 18 000000000000000001
15 14 19 0000000000000000000
15 15 16 0000000000000001

```

Huffman code table 14

not used

Huffman code table 15

```

x y hlen hcod
0 0 3 111
0 1 4 1100
0 2 5 10010
0 3 7 0110101
0 4 7 0101111
0 5 8 01001100
0 6 9 001111100
0 7 9 001101100
0 8 9 001011001
0 9 10 0001111011
0 10 10 0001101100
0 11 11 00001110111
0 12 11 00001101011
0 13 11 00001010001
0 14 12 000001111010
0 15 13 0000000111111
1 0 4 1101
1 1 3 101
1 2 5 10000
1 3 6 011011
1 4 7 0101110
1 5 7 0100100
1 6 8 00111101
1 7 8 00110011
1 8 8 00101010
1 9 9 001000110
1 10 9 000110100
1 11 10 0001010011
1 12 10 0001000001
1 13 10 0000101001
1 14 11 00000111011
1 15 11 00000100100
2 0 5 10011
2 1 5 10001
2 2 5 01111
2 3 6 011000
2 4 7 0101001
2 5 7 0100010
2 6 8 00111011
2 7 8 00110000
2 8 8 00101000
2 9 9 001000000
2 10 9 000110010
2 11 10 0001001110
2 12 10 0000111110
2 13 11 00001010000
2 14 11 00000111000

```

2	15	11	00000100001
3	0	6	011101
3	1	6	011100
3	2	6	011001
3	3	7	0101011
3	4	7	0100111
3	5	8	00111111
3	6	8	00110111
3	7	9	001011101
3	8	9	001001100
3	9	9	000111011
3	10	10	0001011101
3	11	10	0001001000
3	12	10	0000110110
3	13	11	00001001011
3	14	11	00000110010
3	15	11	00000011101
4	0	7	0110100
4	1	6	010110
4	2	7	0101010
4	3	7	0101000
4	4	8	01000011
4	5	8	00111001
4	6	9	001011111
4	7	9	001001111
4	8	9	001001000
4	9	9	000111001
4	10	10	0001011001
4	11	10	0001000101
4	12	10	0000110001
4	13	11	00001000010
4	14	11	00000101110
4	15	11	00000011011
5	0	8	01001101
5	1	7	0100101
5	2	7	0100011
5	3	8	01000010
5	4	8	001111010
5	5	8	00110100
5	6	9	001011011
5	7	9	001001010
5	8	9	000111110
5	9	9	000110000
5	10	10	0001001111
5	11	10	0000111111
5	12	11	00001011010
5	13	11	00000111110
5	14	11	00000101000
5	15	12	000000100110
6	0	9	001111101
6	1	7	0100000
6	2	8	00111100
6	3	8	00111000
6	4	8	00110010
6	5	9	001011100
6	6	9	001001110
6	7	9	001000001
6	8	9	000110111
6	9	10	0001010111
6	10	10	0001000111
6	11	10	0000110011
6	12	11	00001001001
6	13	11	00000110011
6	14	12	000001000110
6	15	12	000000011110
7	0	9	001101101
7	1	8	00110101
7	2	8	00110001
7	3	9	001011110
7	4	9	001011000
7	5	9	001001011
7	6	9	001000010
7	7	10	0001111010
7	8	10	0001011011
7	9	10	0001001001
7	10	10	0000111000
7	11	10	0000101010
7	12	11	00001000000
7	13	11	00000101100
7	14	11	00000010101
7	15	12	000000011001

```
8 0 9 001011010
8 1 8 00101011
8 2 8 00101001
8 3 9 001001101
8 4 9 001001001
8 5 9 000111111
8 6 9 000111000
8 7 10 0001011100
8 8 10 0001001101
8 9 10 0001000010
8 10 10 0000101111
8 11 11 00001000011
8 12 11 00000110000
8 13 12 000000110101
8 14 12 000000100100
8 15 12 000000010100
9 0 9 001000111
9 1 8 00100010
9 2 9 001000011
9 3 9 000111100
9 4 9 000111010
9 5 9 000110001
9 6 10 0001011000
9 7 10 0001001100
9 8 10 0001000011
9 9 11 00001101010
9 10 11 00001000111
9 11 11 00000110110
9 12 11 00000100110
9 13 12 000000100111
9 14 12 000000010111
9 15 12 000000011111
10 0 10 0001101101
10 1 9 000110101
10 2 9 000110011
10 3 9 000101111
10 4 10 0001011010
10 5 10 0001010010
10 6 10 0000111010
10 7 10 0000111001
10 8 10 0000110000
10 9 11 00001001000
10 10 11 00000111001
10 11 11 00000101001
10 12 11 00000010111
10 13 12 000000011011
10 14 13 0000000111110
10 15 12 000000001001
11 0 10 0001010110
11 1 9 000101010
11 2 9 000101000
11 3 9 000100101
11 4 10 0001000110
11 5 10 0001000000
11 6 10 0000110100
11 7 10 0000101011
11 8 11 00001000110
11 9 11 00000110111
11 10 11 00000101010
11 11 11 00000011001
11 12 12 000000011101
11 13 12 000000010010
11 14 12 000000001011
11 15 13 0000000001011
12 0 11 00001110110
12 1 10 0001000100
12 2 9 000011110
12 3 10 0000110111
12 4 10 0000110010
12 5 10 0000101110
12 6 11 00001001010
12 7 11 00001000001
12 8 11 00000110001
12 9 11 00000100111
12 10 11 00000011000
12 11 11 00000010000
12 12 12 000000010110
12 13 12 000000001101
12 14 13 0000000001110
12 15 13 0000000000111
13 0 11 00001011011
```

```

13 1 10 0000101100
13 2 10 0000100111
13 3 10 0000100110
13 4 10 0000100010
13 5 11 00000111111
13 6 11 00000110100
13 7 11 00000101101
13 8 11 00000011111
13 9 12 000000110100
13 10 12 000000011100
13 11 12 000000010011
13 12 12 000000001110
13 13 12 000000001000
13 14 13 0000000001001
13 15 13 0000000000011
14 0 12 000001111011
14 1 11 00000111100
14 2 11 00000111010
14 3 11 00000110101
14 4 11 00000101111
14 5 11 00000101011
14 6 11 00000100000
14 7 11 00000010110
14 8 12 000000100101
14 9 12 000000011000
14 10 12 000000010001
14 11 12 000000001100
14 12 13 0000000001111
14 13 13 0000000001010
14 14 12 000000000010
14 15 13 0000000000001
15 0 12 000001000111
15 1 11 00000100101
15 2 11 00000100010
15 3 11 00000011110
15 4 11 00000011100
15 5 11 00000010100
15 6 11 00000010001
15 7 12 000000011010
15 8 12 000000010101
15 9 12 000000010000
15 10 12 000000001010
15 11 12 000000000110
15 12 13 0000000001000
15 13 13 0000000000110
15 14 13 0000000000010
15 15 13 0000000000000

```

Huffman code table 16

ESC table, linbits=1

x	y	hlen	hcod
0	0	1	1
0	1	4	0101
0	2	6	001110
0	3	8	00101100
0	4	9	001001010
0	5	9	000111111
0	6	10	0001101110
0	7	10	0001011101
0	8	11	00010101100
0	9	11	00010010101
0	10	11	00010001010
0	11	12	000011110010
0	12	12	000011100001
0	13	12	000011000011
0	14	13	0000101111000
0	15	9	000010001
1	0	3	011
1	1	4	0100
1	2	6	001100
1	3	7	0010100
1	4	8	00100011
1	5	9	000111110
1	6	9	000110101
1	7	9	000101111
1	8	10	0001010011
1	9	10	0001001011
1	10	10	0001000100
1	11	11	00001110111

1	12	12	000011001001
1	13	11	00001101011
1	14	12	000011001111
1	15	8	00001001
2	0	6	001111
2	1	6	001101
2	2	7	0010111
2	3	8	00100110
2	4	9	001000011
2	5	9	000111010
2	6	10	0001100111
2	7	10	0001011010
2	8	11	00010100001
2	9	10	0001001000
2	10	11	00001111111
2	11	11	00001110101
2	12	11	00001101110
2	13	12	000011010001
2	14	12	000011001110
2	15	9	000010000
3	0	8	00101101
3	1	7	0010101
3	2	8	00100111
3	3	9	001000101
3	4	9	001000000
3	5	10	0001110010
3	6	10	0001100011
3	7	10	0001010111
3	8	11	00010011110
3	9	11	00010001100
3	10	12	000011111100
3	11	12	000011010100
3	12	12	000011000111
3	13	13	0000110000011
3	14	13	0000101101101
3	15	10	0000011010
4	0	9	001001011
4	1	8	00100100
4	2	9	001000100
4	3	9	001000001
4	4	10	0001110011
4	5	10	0001100101
4	6	11	00010110011
4	7	11	00010100100
4	8	11	00010011011
4	9	12	000100001000
4	10	12	000011110110
4	11	12	000011100010
4	12	13	0000110001011
4	13	13	0000101111110
4	14	13	0000101101010
4	15	9	000001001
5	0	9	001000010
5	1	8	00011110
5	2	9	000111011
5	3	9	000111000
5	4	10	0001100110
5	5	11	00010111001
5	6	11	00010101101
5	7	12	000100001001
5	8	11	00010001110
5	9	12	000011111101
5	10	12	000011101000
5	11	13	0000110010000
5	12	13	0000110000100
5	13	13	0000101111010
5	14	14	00000110111101
5	15	10	0000010000
6	0	10	0001101111
6	1	9	000110110
6	2	9	000110100
6	3	10	0001100100
6	4	11	00010111000
6	5	11	00010110010
6	6	11	00010100000
6	7	11	00010000101
6	8	12	000100000001
6	9	12	000011110100
6	10	12	000011100100
6	11	12	000011011001
6	12	13	0000110000001

6	13	13	0000101101110
6	14	14	00001011001011
6	15	10	0000001010
7	0	10	0001100010
7	1	9	000110000
7	2	10	0001011011
7	3	10	0001011000
7	4	11	00010100101
7	5	11	00010011101
7	6	11	00010010100
7	7	12	000100000101
7	8	12	000011111000
7	9	13	0000110010111
7	10	13	0000110001101
7	11	13	0000101110100
7	12	13	0000101111100
7	13	15	000001101111001
7	14	15	000001101110100
7	15	10	0000001000
8	0	10	0001010101
8	1	10	0001010100
8	2	10	0001010001
8	3	11	00010011111
8	4	11	00010011100
8	5	11	00010001111
8	6	12	000100000100
8	7	12	000011111001
8	8	13	0000110101011
8	9	13	0000110010001
8	10	13	0000110001000
8	11	13	0000101111111
8	12	14	00001011010111
8	13	14	00001011001001
8	14	14	00001011000100
8	15	10	0000000111
9	0	11	00010011010
9	1	10	0001001100
9	2	10	0001001001
9	3	11	00010001101
9	4	11	00010000011
9	5	12	000100000000
9	6	12	000011110101
9	7	13	0000110101010
9	8	13	0000110010110
9	9	13	0000110001010
9	10	13	0000110000000
9	11	14	00001011011111
9	12	13	0000101100111
9	13	14	00001011000110
9	14	13	0000101100000
9	15	11	00000001011
10	0	11	00010001011
10	1	11	00010000001
10	2	10	0001000011
10	3	11	00001111101
10	4	12	000011110111
10	5	12	000011101001
10	6	12	000011100101
10	7	12	000011011011
10	8	13	0000110001001
10	9	14	00001011100111
10	10	14	00001011100001
10	11	14	00001011010000
10	12	15	000001101110101
10	13	15	000001101110010
10	14	14	00000110110111
10	15	10	0000000100
11	0	12	000011110011
11	1	11	00001111000
11	2	11	00001110110
11	3	11	00001110011
11	4	12	000011100011
11	5	12	000011011111
11	6	13	0000110001100
11	7	14	00001011101010
11	8	14	00001011100110
11	9	14	00001011100000
11	10	14	00001011010001
11	11	14	00001011001000
11	12	14	00001011000010
11	13	13	0000011011111

```

11 14 14 00000110110100
11 15 11 00000000110
12 0 12 000011001010
12 1 12 000011100000
12 2 12 000011011110
12 3 12 000011011010
12 4 12 000011011000
12 5 13 0000110000101
12 6 13 0000110000010
12 7 13 0000101111101
12 8 13 0000101101100
12 9 15 000001101111000
12 10 14 00000110111011
12 11 14 00001011000011
12 12 14 00000110111000
12 13 14 00000110110101
12 14 16 0000011011000000
12 15 11 00000000100
13 0 14 000010111101011
13 1 12 000011010011
13 2 12 000011010010
13 3 12 000011010000
13 4 13 0000101110010
13 5 13 00001011111011
13 6 14 00001011011110
13 7 14 00001011010011
13 8 14 00001011001010
13 9 16 0000011011000111
13 10 15 000001101110011
13 11 15 000001101101101
13 12 15 000001101101100
13 13 17 00000110110000011
13 14 15 000001101100001
13 15 11 00000000010
14 0 13 00001011111001
14 1 13 00001011110001
14 2 11 00001100110
14 3 12 0000101111011
14 4 14 00001011010110
14 5 14 00001011010010
14 6 13 0000101100110
14 7 14 00001011000111
14 8 14 00001011000101
14 9 15 000001101100010
14 10 16 0000011011000110
14 11 15 000001101100111
14 12 17 00000110110000010
14 13 15 000001101100110
14 14 14 00000110110010
14 15 11 00000000000
15 0 9 000001100
15 1 8 00001010
15 2 8 00000111
15 3 9 000001011
15 4 9 000001010
15 5 10 0000010001
15 6 10 0000001011
15 7 10 0000001001
15 8 11 00000001101
15 9 11 00000001100
15 10 11 00000001010
15 11 11 00000000111
15 12 11 00000000101
15 13 11 00000000011
15 14 11 00000000001
15 15 8 00000011

```

Huffman code table 17

same as table 16, but linbits=2

Huffman code table 18

same as table 16, but linbits=3

Huffman code table 19

same as table 16, but linbits=4

Huffman code table 20

same as table 16, but linbits=6

Huffman code table 21

same as table 16, but linbits=8

Huffman code table 22

same as table 16, but linbits=10

Huffman code table 23

same as table 16, but linbits=13

Huffman code table 24

ESC table, linbits=4

x	y	hlen	hcod
0	0	4	1111
0	1	4	1101
0	2	6	101110
0	3	7	1010000
0	4	8	10010010
0	5	9	100000110
0	6	9	011111000
0	7	10	0110110010
0	8	10	0110101010
0	9	11	01010011101
0	10	11	01010001101
0	11	11	01010001001
0	12	11	01001101101
0	13	11	01000000101
0	14	12	010000001000
0	15	9	001011000
1	0	4	1110
1	1	4	1100
1	2	5	10101
1	3	6	100110
1	4	7	1000111
1	5	8	10000010
1	6	8	01111010
1	7	9	011011000
1	8	9	011010001
1	9	9	011000110
1	10	10	0101000111
1	11	10	0101011001
1	12	10	0100111111
1	13	10	0100101001
1	14	10	0100010111
1	15	8	00101010
2	0	6	101111
2	1	5	10110
2	2	6	101001
2	3	7	1001010
2	4	7	1000100
2	5	8	10000000
2	6	8	01111000
2	7	9	011011101
2	8	9	011001111
2	9	9	011000010
2	10	9	010110110
2	11	10	0101010100
2	12	10	0100111011
2	13	10	0100100111
2	14	11	01000011101
2	15	7	0010010
3	0	7	1010001
3	1	6	100111
3	2	7	1001011
3	3	7	1000110
3	4	8	10000110
3	5	8	01111101
3	6	8	01110100
3	7	9	011011100
3	8	9	011001100
3	9	9	010111110
3	10	9	010110010
3	11	10	0101000101
3	12	10	0100110111
3	13	10	0100100101

3	14	10	0100001111
3	15	7	0010000
4	0	8	10010011
4	1	7	1001000
4	2	7	1000101
4	3	8	10000111
4	4	8	01111111
4	5	8	01110110
4	6	8	01110000
4	7	9	011010010
4	8	9	011001000
4	9	9	010111100
4	10	10	0101100000
4	11	10	0101000011
4	12	10	0100110010
4	13	10	0100011101
4	14	11	01000011100
4	15	7	0001110
5	0	9	100000111
5	1	7	1000010
5	2	8	10000001
5	3	8	01111110
5	4	8	01110111
5	5	8	01110010
5	6	9	011010110
5	7	9	011001010
5	8	9	011000000
5	9	9	010110100
5	10	10	0101010101
5	11	10	0100111101
5	12	10	0100101101
5	13	10	0100011001
5	14	10	0100000110
5	15	7	0001100
6	0	9	011111001
6	1	8	01111011
6	2	8	01111001
6	3	8	01110101
6	4	8	01110001
6	5	9	011010111
6	6	9	011001110
6	7	9	011000011
6	8	9	010111001
6	9	10	0101011011
6	10	10	0101001010
6	11	10	0100110100
6	12	10	0100100011
6	13	10	0100010000
6	14	11	01000001000
6	15	7	0001010
7	0	10	0110110011
7	1	8	01110011
7	2	8	01101111
7	3	8	01101101
7	4	9	011010011
7	5	9	011001011
7	6	9	011000100
7	7	9	010111011
7	8	10	0101100001
7	9	10	0101001100
7	10	10	0100111001
7	11	10	0100101010
7	12	10	0100011011
7	13	11	01000010011
7	14	11	00101111101
7	15	8	00010001
8	0	10	0110101011
8	1	9	011010100
8	2	9	011010000
8	3	9	011001101
8	4	9	011001001
8	5	9	011000001
8	6	9	010111010
8	7	9	010110001
8	8	9	010101001
8	9	10	0101000000
8	10	10	0100101111
8	11	10	0100011110
8	12	10	0100001100
8	13	11	01000000010
8	14	11	00101111001

8	15	8	00010000
9	0	10	0101001111
9	1	9	011000111
9	2	9	011000101
9	3	9	010111111
9	4	9	010111101
9	5	9	010110101
9	6	9	010101110
9	7	10	0101001101
9	8	10	0101000001
9	9	10	0100110001
9	10	10	0100100001
9	11	10	0100010011
9	12	11	01000001001
9	13	11	00101111011
9	14	11	00101110011
9	15	8	00001011
10	0	11	01010011100
10	1	9	010111000
10	2	9	010110111
10	3	9	010110011
10	4	9	010101111
10	5	10	0101011000
10	6	10	0101001011
10	7	10	0100111010
10	8	10	0100110000
10	9	10	0100100010
10	10	10	0100010101
10	11	11	01000010010
10	12	11	00101111111
10	13	11	00101110101
10	14	11	00101101110
10	15	8	00001010
11	0	11	01010001100
11	1	10	0101011010
11	2	9	010101011
11	3	9	010101000
11	4	9	010100100
11	5	10	0100111110
11	6	10	0100110101
11	7	10	0100101011
11	8	10	0100011111
11	9	10	0100010100
11	10	10	0100000111
11	11	11	01000000001
11	12	11	00101110111
11	13	11	00101110000
11	14	11	00101101010
11	15	8	00000110
12	0	11	01010001000
12	1	10	0101000010
12	2	10	0100111100
12	3	10	0100111000
12	4	10	0100110011
12	5	10	0100101110
12	6	10	0100100100
12	7	10	0100011100
12	8	10	0100001101
12	9	10	0100000101
12	10	11	01000000000
12	11	11	00101111000
12	12	11	00101110010
12	13	11	00101101100
12	14	11	00101100111
12	15	8	00000100
13	0	11	01001101100
13	1	10	0100101100
13	2	10	0100101000
13	3	10	0100100110
13	4	10	0100100000
13	5	10	0100011010
13	6	10	0100010001
13	7	10	0100001010
13	8	11	01000000011
13	9	11	00101111100
13	10	11	00101110110
13	11	11	00101110001
13	12	11	00101101101
13	13	11	00101101001
13	14	11	00101100101
13	15	8	00000010

```

14 0 12 010000001001
14 1 10 0100011000
14 2 10 0100010110
14 3 10 0100010010
14 4 10 0100001011
14 5 10 0100001000
14 6 10 0100000011
14 7 11 00101111110
14 8 11 00101111010
14 9 11 00101110100
14 10 11 00101101111
14 11 11 00101101011
14 12 11 00101101000
14 13 11 00101100110
14 14 11 00101100100
14 15 8 00000000
15 0 8 00101011
15 1 7 0010100
15 2 7 0010011
15 3 7 0010001
15 4 7 0001111
15 5 7 0001101
15 6 7 0001011
15 7 7 0001001
15 8 7 0000111
15 9 7 0000110
15 10 7 0000100
15 11 8 00000111
15 12 8 00000101
15 13 8 00000011
15 14 8 00000001
15 15 4 0011

```

Huffman code table 25

same as table 24, but linbits=5

Huffman code table 26

same as table 24, but linbits=6

Huffman code table 27

same as table 24, but linbits=7

Huffman code table 28

same as table 24, but linbits=8

Huffman code table 29

same as table 24, but linbits=9

Huffman code table 30

same as table 24, but linbits=11

Huffman code table 31

same as table 24, but linbits=13

Table 3-B.8. Layer III scalefactor bands

These tables list the width of each scalefactor band. There are 21 bands at each sampling frequency for long (type 0,1 or 3) windows and 12 bands each for short windows.

Table 3-B.8a. 32kHz sampling rate

long blocks:

scale factor band	width of band	index of start	index of end
----------------------	------------------	-------------------	-----------------

0	4	0	3
1	4	4	7
2	4	8	11
3	4	12	15
4	4	16	19
5	4	20	23
6	6	24	29
7	6	30	35
8	8	36	43
9	10	44	53
10	12	54	65
11	16	66	81
12	20	82	101
13	24	102	125
14	30	126	155
15	38	156	193
16	46	194	239
17	56	240	295
18	68	296	363
19	84	364	447
20	102	448	549

short blocks:

scale factor band	width of band	index of start	index of end
0	4	0	3
1	4	4	7
2	4	8	11
3	4	12	15
4	6	16	21
5	8	22	29
6	12	30	41
7	16	42	57
8	20	58	77
9	26	78	103
10	34	104	137
11	42	138	179

Table 3-B.8b. 44.1kHz sampling rate

long blocks:

scale factor band	width of band	index of start	index of end
0	4	0	3
1	4	4	7
2	4	8	11
3	4	12	15

4	4	16	19
5	4	20	23
6	6	24	29
7	6	30	35
8	8	36	43
9	8	44	51
10	10	52	61
11	12	62	73
12	16	74	89
13	20	90	109
14	24	110	133
15	28	134	161
16	34	162	195
17	42	196	237
18	50	238	287
19	54	288	341
20	76	342	417

short blocks:

scale factor band	width of band	index of start	index of end
0	4	0	3
1	4	4	7
2	4	8	11
3	4	12	15
4	6	16	21
5	8	22	29
6	10	30	39
7	12	40	51
8	14	52	65
9	18	66	83
10	22	84	105
11	30	106	135

Table 3-B.8c. 48 kHz sampling rate

long blocks:

scale factor band	width of band	index of start	index of end
0	4	0	3
1	4	4	7
2	4	8	11
3	4	12	15
4	4	16	19
5	4	20	23

6	6	24	29
7	6	30	35
8	6	36	41
9	8	42	49
10	10	50	59
11	12	60	71
12	16	72	87
13	18	88	105
14	22	106	127
15	28	128	155
16	34	156	189
17	40	190	229
18	46	230	275
19	54	276	329
20	54	330	383

short blocks:

scale factor band	width of band	index of start	index of end
0	4	0	3
1	4	4	7
2	4	8	11
3	4	12	15
4	6	16	21
5	6	22	27
6	10	28	37
7	12	38	49
8	14	50	63
9	16	64	79
10	20	80	99
11	26	100	125

Table 3-B.9 Layer III coefficients for aliasing reduction:

(i)	ci
0	-0.6
1	-0.535
2	-0.33
3	-0.185
4	-0.095
5	-0.041
6	-0.0142
7	-0.0037

The butterfly coefficients c_{si} and c_{ai} are calculated as follows:

$$cs_i = \frac{1}{\sqrt{1 + c_i^2}} \quad ca_i = \frac{c_i}{\sqrt{1 + c_i^2}}$$