

Vending Machine Controller

1. Introduction

The following is a detailed specification for a simple vending machine controller. The vending machine will dispense cans of soda when the correct amount of money is inserted. The vending machine controller interfaces with the COIN_RECEIVER, COIN_CHANGER, and SODA_DROP components. These components need not be designed. The COIN_RECEIVER will accept nickels, dimes and quarters as input. The COIN_CHANGER will return nickel only, when the accumulated value of the coins input to the receiver exceeds the price of the soda and change needs to be given back. The SODA_DROP component will dispense a can of soda when the correct amount of change is present.

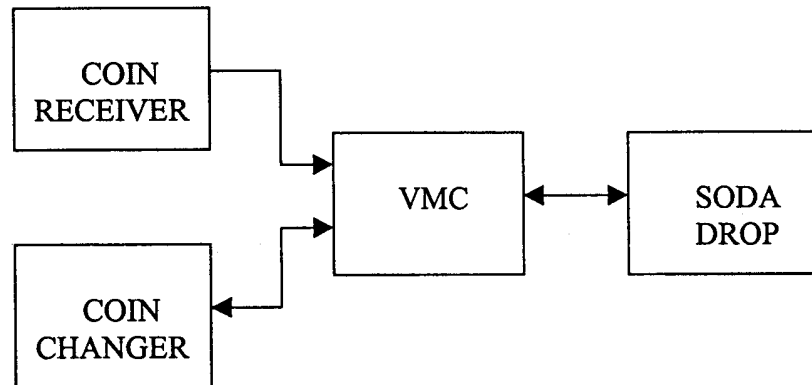

2. Pin Description

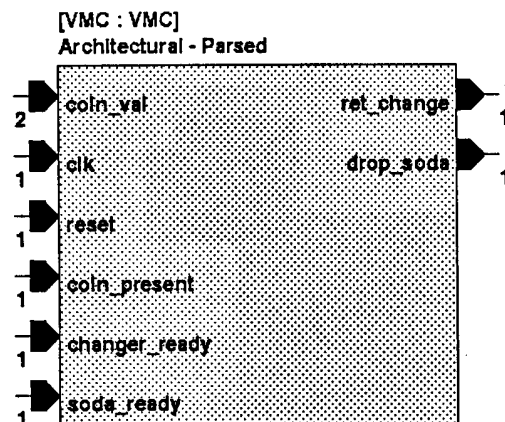



Pin Name	Size	Type	Function
clk	1	Input	System clock
reset	1	Input	Asynchronous reset
coin_present	1	Input	Input flag to VMC from COIN_RECEIVER to show that coin is present in the coin receiver
coin_val	2	Input	Input data from COIN_RECEIVER to show the monetary value of the current coin present in the coin receiver
changer_ready	1	Input	Flag from COIN_CHANGER to notify that it is ready to receive the <i>ret change</i>
ret_change	1	Output	Control signal to COIN_CHANGER to return a nickel
soda_ready	1	Input	Flag from SODA_DROP to notify VMC of the status of soda drop mechanism
drop_soda	1	Output	Notify the soda drop mechanism to drop the soda requested

3 VMC Operation

The VMC can be broken down into two components: an ALU and a controller components. The controller controls the mechanism of the vending machine. The COIN_RECEIVER component sends a "coin_present" signal to the controller telling it that a coin is present, then calculates the amount inserted and sends it to the ALU. This 2-bit wide signal ("coin_val") represents the value of the coin inserted. The ALU adds the value of this signal to an accumulator register whenever it receives "add_acc" signal from the controller. The accumulator register is compared to the reference price of the soda (in this case 55 cents). If the money tendered is greater than the price of the soda, a signal "GT" is sent to the controller. The controller in turn sends a signal "ret_change" to the coin changer, which returns a nickel to the customer and asserts "dec_acc" back to the ALU. The ALU then decrements the accumulator register by the price of one nickel and compares it with the reference price again. This process is continued until the difference is '0'. When it is '0', the controller sends the signal "drop_soda" to the soda drop mechanism and checks the signal "soda_ready". If "soda_ready" has not been set, "drop_soda" is asserted again. If "soda_ready" has been set, the ALU accumulator register is cleared and is ready for the next transaction. The block diagram shows the I/O connections of the system.

