

Name (please print): \_\_\_\_\_ Total points: \_\_\_/40

**Instructions**

This is a CLOSED BOOK and CLOSED NOTES quiz. However, you may use calculators, scratch paper, and the green MIPS reference card from your textbook. Ask the instructor if you have any questions. Good luck!

1. (20 points) Assume the following floating-point format:

1 bit	6 bits	8 bits
sign	exponent bias=31	significand

- a. What is the precision of this format?

$2^{-8}$  (assume round down)

- b. What is the range of this format?

$2^{-31}$  to  $2^{32}$  (assume no de-normalized numbers)

- c. Encode  $-5.3_{10}$  into this format (round down).

converted=101.0100110,  
sign=1, exp=2 (33 after biasing), sig=010100110

- d. What is the rounding error of the value in this representation?

$-5.3 - (-5.296875) = -0.003125$

2. (10 points) Write a sequence of MIPS assembly code that will detect overflow for **unsigned addition**.

```
addu $s0,$s1,$s2
nor $t0,$s1,$0
sltu $t0,$t0,$s2
bnez $t0,overflow
```

3. (10 points) Assume the following divider design:

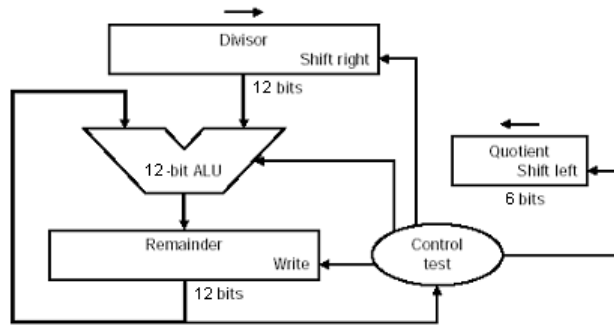

Assume the divisor and remainder registers are 12 bits and the quotient register is 6 bits. Give the values of each register for each step of the divide operation. You may use **decimal** or **binary** representation. Assume the divider is dividing **51** by **11** (assume all register values are unsigned).

Remainder Register	Divisor Register	Quotient Register
51	$11 \cdot 2^6 = 704$	0
$51 - 704 = -653$ (1 <sup>st</sup> )	704	0
$-653 + 704 = 51$	704	(shift in 0) 0
51	$704 / 2 = 352$	0
$51 - 352 = -301$ (2 <sup>nd</sup> )	352	0
$-301 + 352 = 51$	352	(shift in 0) 0
51	$352 / 2 = 176$	0
$51 - 176 = -125$ (3 <sup>rd</sup> )	176	0
$-125 + 176 = 51$	176	(shift in 0) 0
51	$176 / 2 = 88$	0
$51 - 88 = -37$ (4 <sup>th</sup> )	88	0
$-37 + 88 = 51$	88	(shift in 0) 0
51	$88 / 2 = 44$	0
$51 - 44 = 7$ (5 <sup>th</sup> )	44	0
7	44	(shift in 1) 1
7	$44 / 2 = 22$	1
$7 - 22 = -15$ (6 <sup>th</sup> )	22	1
$-15 + 22 = 7$	22	(shift in 0) 2
7	$22 / 2 = 11$	2
$7 - 11 = -4$ (7 <sup>th</sup> )	11	2
$-4 + 11 = 7$	11	(shift in 0) 4