



Causality in Communication: The Agent-Encapsulated Bayesian Network Model

Scott Langevin

Oculus Info, Inc.

Toronto, Ontario, Canada

Marco Valtorta

mgv@cse.sc.edu

Department of Computer Science and Engineering

University of South Carolina, Columbia, South Carolina, USA

June 10, 2011



Outline

- Cooperative intelligent agents
- AEBNs (Agent Encapsulated Bayesian Networks) and MSBNs (Multiply Sectioned Bayesian Networks) as examples of loosely coupled and tightly coupled agent systems
- The Oracular Assumption vs. Intervention
- Research Goals and Status:
 - Related Work
 - Future Work



Agents

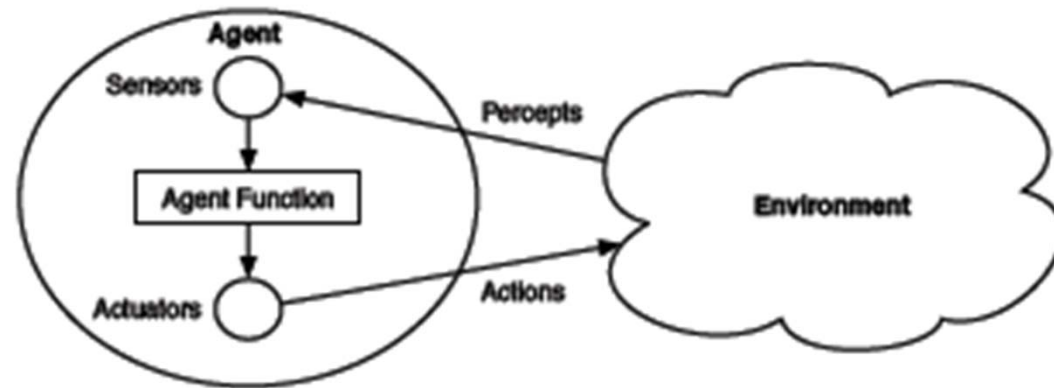

- An intelligent agent has an internal representation of the environment
- It senses
- It reasons about the true state of the environment
- It acts based on goals and belief of the true state of the environment



Cooperative Agents

- Our agents form cooperative multiagent system and use Bayesian networks or influence diagrams for internal knowledge representation
- Method of distributed inference over individually designed probabilistic graphical models
- Potential applications
 - Distributed pattern recognition, e.g.: Elderly fall detection
 - Distributed interpretation, e.g.: Intrusion detection, Threat assessment
 - Sensor fusion



Multiagent Systems

- How do agents represent knowledge?
- How do agents communicate?
- Whom should agents be allowed to communicate with?
- What is the purpose of the communication?
- How should messages be processed?
- Is global consistency desired, and if so how is global consistency maintained?



Bayesian Networks

- Way of representing uncertain knowledge
- Divide world into variables of interest
- Each variable has a set of mutually exclusive and exhaustive states
- Causal relationships are represented in a directed acyclic graph
- Directed edge is made from variable that has causal relationship to another
- Strength of casual relationships is represented as conditional probability tables
- Product of all conditional probability tables is a joint probability table over the domain
- Typical task is entering evidence and calculating marginal probability distribution for all variables

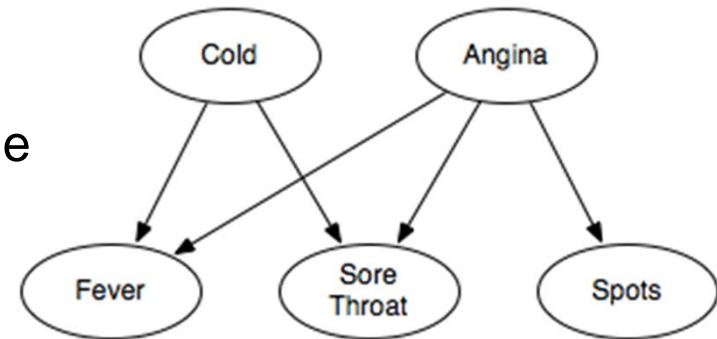



Agent-Encapsulated Bayesian Networks

- Agents represent knowledge using Bayesian networks
- Each agents BN is partitioned into Input (I), Output (O) and Private variables (L)
- Agents communicate via messages that are probability distributions on the shared variables (input and output variables)
- Each agent has correct view of its output variables and shares that view with interested agents (oracular assumption)
- Agents are organized into publisher/subscriber hierarchy
- Topology of communication is a DAG



Types of Evidence

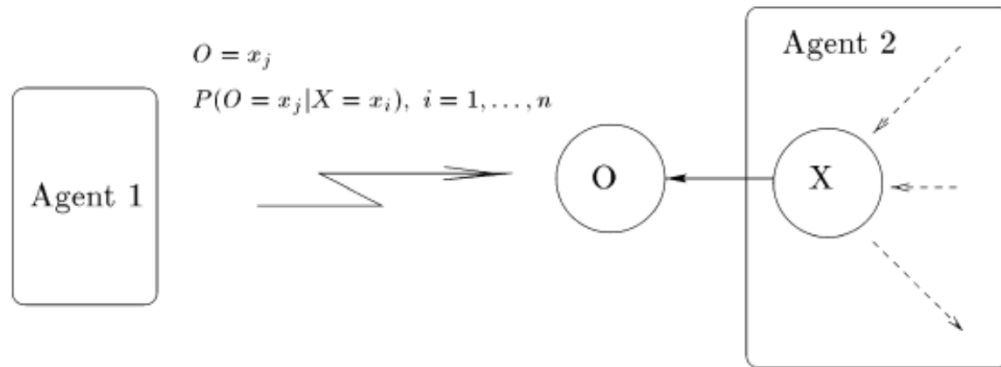

- Virtual evidence: it can be improved by other observations in the receiving agent

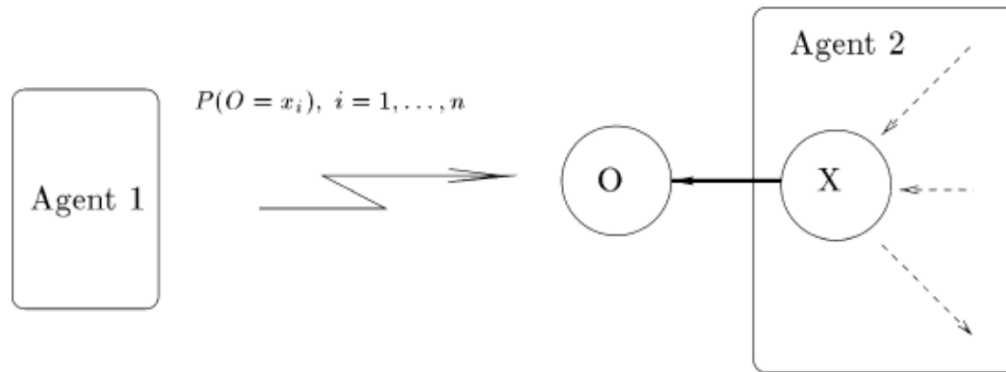

- Soft evidence: it cannot be modified by any other observation in the receiving agent

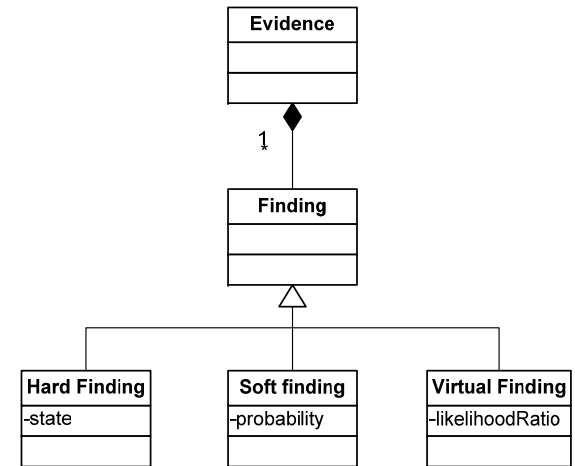



AEBN

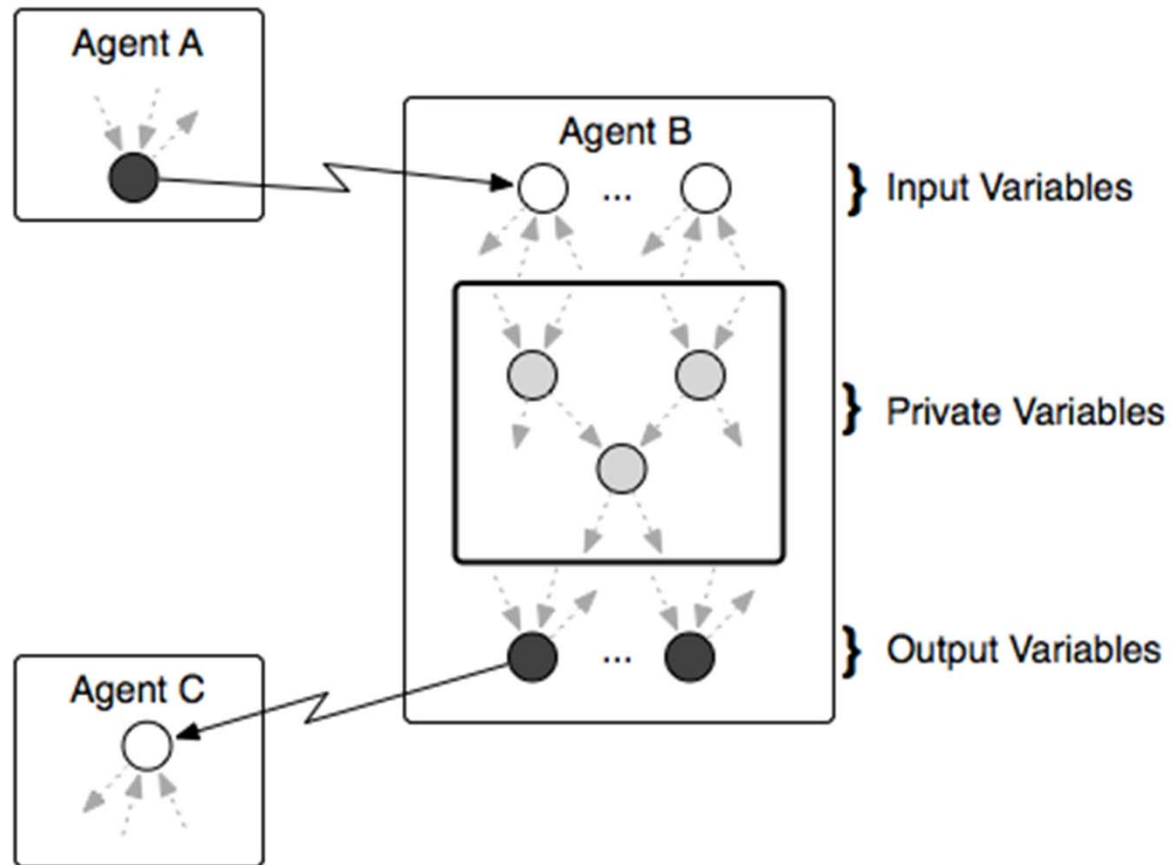



Belief Update

- Agents replace current belief on shared variables with the publishing agent's belief
- Shared beliefs are treated as soft evidence
- Each subscribing agent updates its internal model so it is consistent with the beliefs of the publishing agent to which it subscribes: $Q(E_1), \dots, Q(E_n)$, $I = \cup \text{dom}(E_i)$

$$Q^*(V) = P(V \setminus I | I) \cdot Q(I) = \frac{P(V)}{P(I)} \cdot Q_I^*(I)$$

- $Q^*_I(I)$ is I_1 -projection of $P(I)$ having $Q(E_1), \dots, Q(E_n)$ as marginals: $Q^*_I(I)$ minimizes the change of the agent's belief while respecting the evidence received



Belief Update

Jeffrey's Rule

$$Q(A) = \sum_B P(A|B) \cdot Q(B)$$

where $Q(B)$ is a soft finding and $P(A|B)$ is invariant given the soft finding

Iterative Proportional Fitting Procedure

Given $P(S_1), \dots, P(S_k)$, where each $P(S_i)$ is soft evidence,

$$Q_0(V) = P(V)$$

$$Q_i(V) = Q_{i-1}(V) \cdot \frac{P(S_j)}{Q_{i-1}(S_j)}$$

where $j = (i - 1) \bmod k + 1$



Communication Graphs

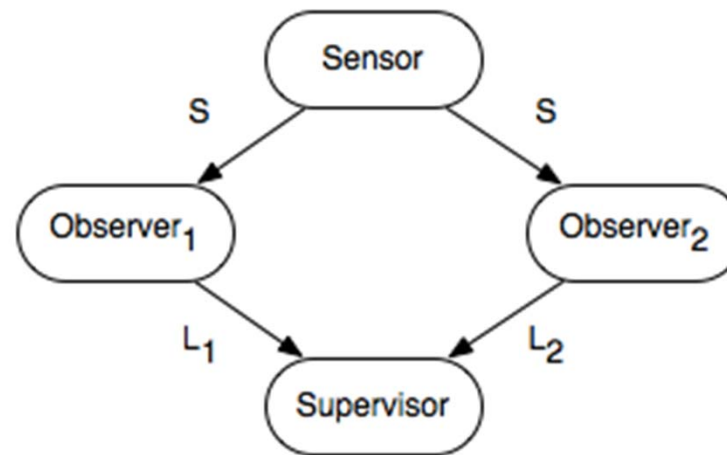



Multiply Sectioned Bayesian Networks

Xiang's Five Basic Assumptions

1. Each agent's belief is represented by probability
2. Agents communicate with concise messages that are joint probability distributions over the variables they share
3. A simpler agent organization is preferred in which agent communication by concise message passing is achievable
4. Each agent represents its knowledge dependence structure as a DAG
5. Within each agent's subdomain, a JPD is consistent with the agent's belief. For shared variables, a JPD supplements an agent's knowledge with the knowledge of other agents



Multiply Sectioned Bayesian Networks

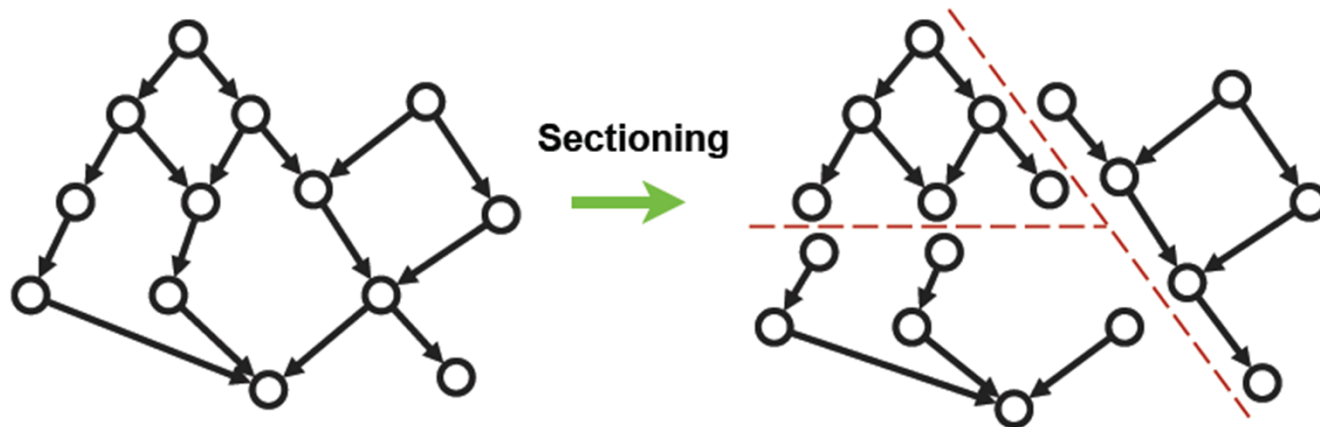

Every subnet is sectioned from a global BN

- Strictly consistent subnets
- Exactly identical shared variables with the same distribution
- All parents of shared variables must appear in one subnet
- Interface between subnets must d-separate
- Agent decomposition **must** conform to a hypertree MSDAG



Basic Assumptions for Our Agent Model

1. Each agent's belief is represented by probability
2. ~~Agents communicate with concise messages that are joint probability distributions over the variables they share~~
3. ~~A simpler agent organization is preferred in which agent communication by concise message passing is achievable~~
4. Each agent represents its knowledge dependence structure as a DAG
5. Within each agent's subdomain, a JPD is consistent with the agent's belief. For shared variables, a JPD supplements an agent's knowledge with the knowledge of other agents
6. Oracular assumption



The Oracular Assumption

- Each agent has correct view of its output variables and shares that view with interested agents (oracular assumption)
- Agents are organized into publisher/subscriber hierarchy
- Topology of communication is a DAG
- Variables in parent agents are not affected by variables in descendant agents.

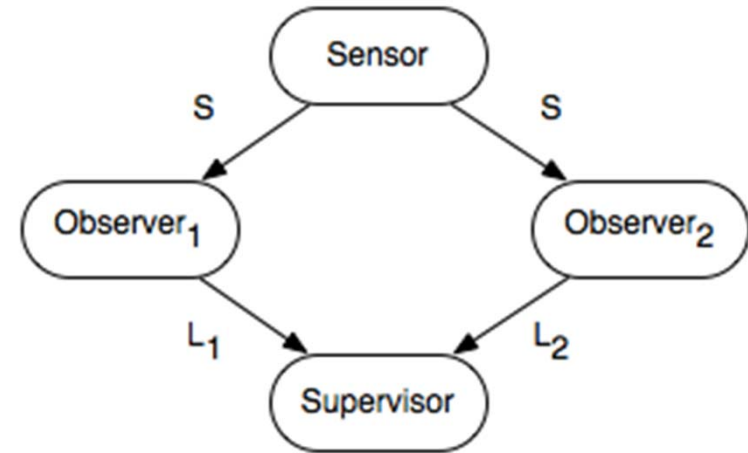



The Oracular Assumption

- Let A_i and A_j be two distinct agents, let V_i and V_j be the sets of variables in agents A_i and A_j , respectively, and let $W_i \subseteq V_i$ and $W_j \subseteq V_j$. Then if there is no directed path in the communication graph from A_j to A_i , any changes (whether by observation or by intervention) in the state of the variables in W_j do not affect the state of the variables in W_i .
- This is not a symmetric relation, and therefore cannot be represented by any independence relation.



The Oracular Assumption and Causal Bayesian Networks

- In a causal Bayesian network, when a variable is set (by external intervention), the parents of that variable are disconnected from it; more precisely, the result of the intervention is to create a new Bayesian network in which we remove the edges incoming into a variable that is set
- However, in a causal Bayesian network, when a variable is set by intervention, some of the parent variables may be affected through backdoor paths. In an AEBN, there is no possibility for a variable in an agent to be affected by a descendent agent.



Keshan Disease

If *Serum Selenium* is set by intervention, the links between it and both *Diet* and *Region of China* are cut

Still, there is a dependency between *Serum Selenium* and *Region of China* when *ECG* is known

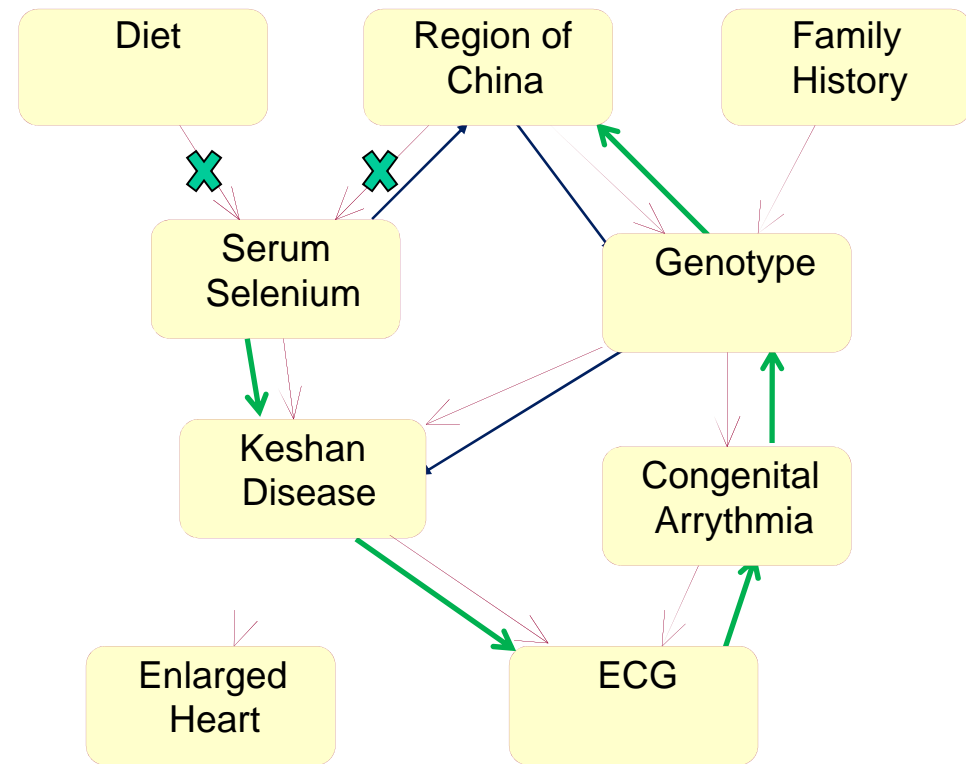

Backdoor Path 1

Backdoor Path 2



MSBNs vs AEBNs

MSBN	AEBN
Disadvantages	
Tree topology	Rumor problem
Limited autonomy	Additional independence assumptions
Restrictive agent decomposition	
Advantages	
No rumor problem	Graph topologies
Exact inferencing as BN	Loosely coupled agents



Other Approaches to Probabilistic Multiagent Systems

<i>Name</i>	<i>Granularity</i>	<i>Topological Restrictions</i>	<i>Constraints on Independence Relation</i>	<i>Purpose</i>	<i>Scalability</i>	<i>Reference</i>
<i>Bayesian Network (BN)</i>	Individual Variable	DAG (of variables)	Local Markov condition (d-separation)	Efficient representation of multivariate probability distribution	Poor	F.V. Jensen. <i>Bayesian Networks and Decision Graphs</i>. Springer, 2001.
<i>Multiply Sectioned Bayesian Network (MSBN)</i>	Bayesian Network (BN)	Tree (of BNs)	D-separation, on composition of BNs	Efficient distribution of computation among processors	Good: distributed computation, if tree decomposition is possible	Y. Xiang and V. Lesser. “Justifying Multiply Sectioned Bayesian Networks.” ICMAS-2000.
<i>Multiple-Entity Bayesian Networks (MEBN)</i>	Bayesian Network Fragments (BNFragments)	DAG (of BNFragments)	D-separation on composition of BNs; encapsulation	Distributed representation of Bayesian networks	Mediocre: representation decomposed, computation centralized	K. Laskey, S. Mahoney, and E. Wright. “Hypothesis Management in Situation-Specific Network Construction.” UAI-01.
<i>Agent-Encapsulated Bayesian Networks (AEBN)</i>	Bayesian Network (BN)	DAG (of BNs)	Shared variables independent of variables in descendant BNs given parent BNs; encapsulation	Construction of interpretation models by collaborating agents	Very Good: distributed computation, distributed representation	Scott Langevin. “Knowledge Representation, Communication, and Update in Probability-Based Multiagent Systems.” PhD Dissertation, University of South Carolina, 2010.
<i>Decentralized Sensing Networks (DSN)</i>	Sensor	Undirected graph (of sensors)	None: Non-probabilistic approach	Distributed sensing and data fusion	Poor: rumor problem is unsolvable in DSNs	S. Utete. “Local Information Processing for Decision Making in Decentralizing Sensing Networks.” IEA/AIE-98.



Research Goals

- Design of a cooperative multiagent system where agents use Bayesian networks or influence diagrams for internal knowledge representation
- Method of distributed inference over individually designed probabilistic graphical models
- Development of efficient methods to perform soft evidential update on Bayesian networks and influence diagrams



Related Work

- Algorithms for efficient soft evidential update
- Algorithms to identify rumors in AEBN systems and compensate for them
- Implementation of the AEBN framework (in Java)
- Evaluation:
 - Comparison of AEBN and MSBN implementations of a multiagent system for threat assessment

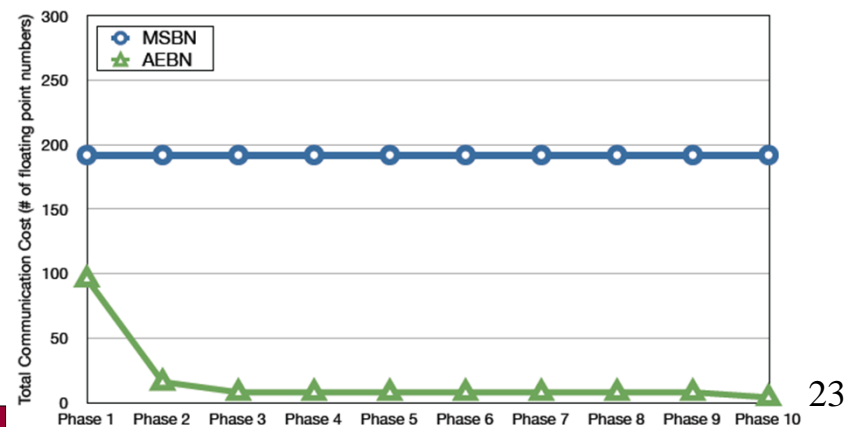
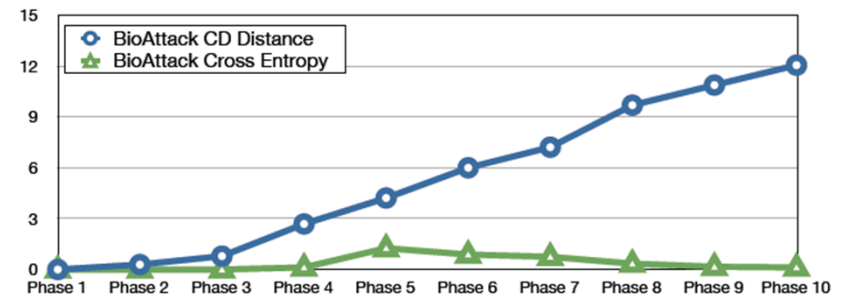
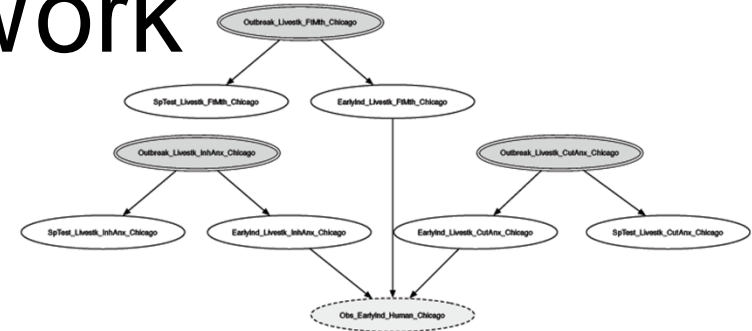



Future Work

- Extend soft evidential update to Influence diagrams
- Characterize the joint probability distribution of shared variables represented by an AEBN system--- recent research in identifiability in causal Bayesian networks shows promise in proving stronger properties of AEBNs
- Implementation issues of AEBNs should be explored such as dynamic multiagent networks, handling of communication failures, and resolving inconsistent or conflicting evidence



Thank You!



Scott Langevin and Marco Valtorta
scott.langevin@gmail.com and mgv@cse.sc.edu